



**QUEEN'S
UNIVERSITY
BELFAST**

Loss-of-Mains Protection System by Application of Phasor Measurement Unit Technology with Experimentally Assessed Threshold Settings

Laverty, D., Best, R., & Morrow, D. J. (2015). Loss-of-Mains Protection System by Application of Phasor Measurement Unit Technology with Experimentally Assessed Threshold Settings. *IET Generation, Transmission and Distribution*, 9(2), 146-153. <https://doi.org/10.1049/iet-gtd.2014.0106>

Published in:
IET Generation, Transmission and Distribution

Document Version:
Publisher's PDF, also known as Version of record

Queen's University Belfast - Research Portal:
[Link to publication record in Queen's University Belfast Research Portal](#)

Publisher rights

Copyright 2015 the authors.

This is an open access article published by the IET under the Creative Commons Attribution License (<http://creativecommons.org/licenses/by/3.0/>), which permits unrestricted use, distribution and reproduction in any medium, provided the author and source are cited.

General rights

Copyright for the publications made accessible via the Queen's University Belfast Research Portal is retained by the author(s) and / or other copyright owners and it is a condition of accessing these publications that users recognise and abide by the legal requirements associated with these rights.

Take down policy

The Research Portal is Queen's institutional repository that provides access to Queen's research output. Every effort has been made to ensure that content in the Research Portal does not infringe any person's rights, or applicable UK laws. If you discover content in the Research Portal that you believe breaches copyright or violates any law, please contact openaccess@qub.ac.uk.

Open Access

This research has been made openly available by Queen's academics and its Open Research team. We would love to hear how access to this research benefits you. – Share your feedback with us: <http://go.qub.ac.uk/oa-feedback>

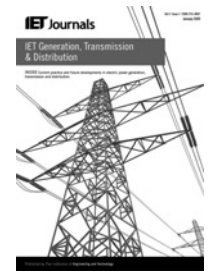

Loss-of-mains protection system by application of phasor measurement unit technology with experimentally assessed threshold settings

David M. Laverty, Robert J. Best, D. John Morrow

School of Electronic, Electrical Engineering and Computer Science, Queen's University Belfast, Belfast, BT9 5AH, UK
E-mail: david.laverty@qub.ac.uk

Abstract: Loss-of-mains protection is an important component of the protection systems of embedded generation. The role of loss-of-mains is to disconnect the embedded generator from the utility grid in the event that connection to utility dispatched generation is lost. This is necessary for a number of reasons, including the safety of personnel during fault restoration and the protection of plant against out-of-synchronism reclosure to the mains supply. The incumbent methods of loss-of-mains protection were designed when the installed capacity of embedded generation was low, and known problems with nuisance tripping of the devices were considered acceptable because of the insignificant consequence to system operation. With the dramatic increase in the installed capacity of embedded generation over the last decade, the limitations of current islanding detection methods are no longer acceptable. This study describes a new method of loss-of-mains protection based on phasor measurement unit (PMU) technology, specifically using a low cost PMU device of the authors' design which has been developed for distribution network applications. The proposed method addresses the limitations of the incumbent methods, providing a solution that is free of nuisance tripping and has a zero non-detection zone. This system has been tested experimentally and is shown to be practical, feasible and effective. Threshold settings for the new method are recommended based on data acquired from both the Great Britain and Ireland power systems.

1 Introduction

Loss-of-mains protection is an important requirement for operation of embedded generation. Embedded generation refers to generation that is connected to the distribution grid, such as wind turbines, photovoltaics, small hydro and diesel generator sets. The role of loss-of-mains protection is to prevent the formation of 'power islands'. This is the scenario when a section of distribution network has become disconnected from utility supply, but utility customers continue to be energised by an embedded generator. This is undesirable from the point-of-view of power quality, and also poses serious hazards to personnel. Thus, embedded generators are required to detect when connection to utility dispatch generation is lost (i.e. loss-of-mains) and then disconnect themselves from the utility grid.

Over the past decade there has been a dramatic increase in the installed capacity of embedded generation on utility networks around the world. This has been prompted for a number of reasons, in some countries such as the UK and Ireland by the growth in renewable generation. The loss-of-mains technologies in use today have known issues regarding nuisance tripping which were tolerable when the installed capacity of embedded generation was low but are no longer appropriate for today's power systems. Of specific concern is the possibility of cascade tripping of embedded generation. Ireland regularly operates with 50%

of demand supplied by non-synchronous generation, mainly wind [1]. Under such conditions, widespread nuisance tripping of loss-of-mains protection could lead to a large shortfall in generation.

This paper describes the islanding problem and discusses current methods of loss-of-mains protection and their limitations. Alternative methods that have been proposed in literature make improvements, but the authors suggest a new method that continuously monitors that the embedded generator is in synchronism with the utility by means of synchrophasors. Thresholds for this new detector are established from experimental data gathered by phasor measurement unit (PMU), under both normal system operation and system wide transients. A prototype detector is implemented and shown to respond appropriately.

2 Islanding problem

Loss-of-mains protection is described here by means of a simplified distribution network diagram, Fig. 1. A fault has occurred on the distribution line between 'A' and 'B'. Protection has operated at 'A' and 'B' to isolate the line. An embedded generator exists downstream of 'B'. This generator has continued to supply its local load, and is also feeding the remaining utility network and utility network loads. A generator is said to have become islanded when

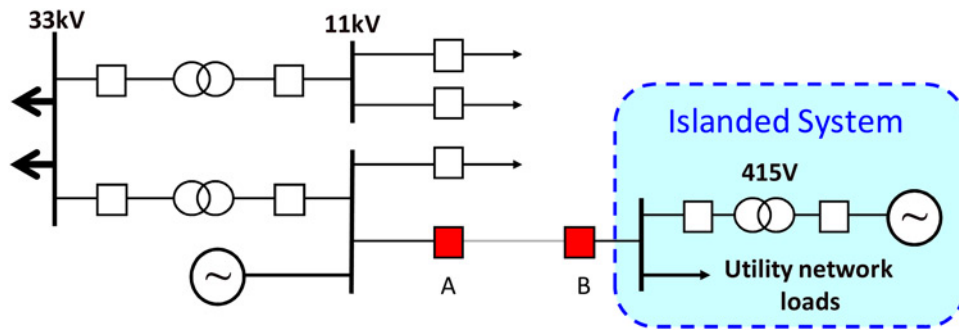

Fig. 1 Example of islanding scenario

there is no electrical connection between it and utility dispatched generation.

Islanding is potentially hazardous for a number of reasons that are discussed fully in literature [2, 3]. The main concerns include risks to the safety of personnel, unearthed operation, risks to plant in the islanded system because of power quality, and also severe damage or destruction of equipment because of out-of-synchronism reclosure of the islanded system back onto mains supply. Thus it is important that when an embedded generator loses connection to utility supply that it disconnects from the utility network. Continued supply to its owner's premises is possible once isolated from the utility. Indeed, this is mandated by Engineering Recommendation G59/3 [4] in the UK, and by IEEE 1547.4 [5] in the USA.

With the introduction of G59/2-1 in January 2013 followed by the recent G59/3, which see the 'widening' of threshold settings, the authors are of the opinion that ROCOF and VS, while being a suitable solution to the loss-of-mains problem at their time of introduction, will be of limited use in future power systems where frequency is much more dynamic.

3 Methods of islanding detection

3.1 Traditional islanding detection

There are two dominant forms of loss-of-mains protection, rate-of-change-of-frequency (ROCOF) and vector shift (VS). Both techniques operate on the principle that at the moment of island formation there will be an imbalance between islanded load and islanded generation. Islanding is inferred from a change in the pattern of zero-crossings of the voltage waveform.

(1) *VS*: VS relies on a power imbalance at the moment of island formation. Fig. 2 shows the theory of VS in an equivalent circuit. Before the power island is formed, switch 'A' is closed and the load current, I_L , is supplied both by the local generator, I_G , and the grid, I_g . The load angle of the generator is θ . After the power island is formed, the load current is supplied entirely by the generator. The change in load current causes the voltage at the generator terminals to shift by $\Delta\theta$ because of the reactance of the generator, X_d . The typical threshold setting for a vector shift relay is typically $\pm 6^\circ$. It should be noted that the theory of operation of vector shift assumes a synchronous machine, and is not directly applicable to inverter-based systems.

(2) *ROCOF*: ROCOF islanding detection works by determining the variation in frequency of the voltage at the

generator terminals, and if this exceeds a certain threshold then a loss-of-mains event is said to have occurred. The method assumes that there is a power imbalance at the moment of island formation, such that the load in the islanded system does not match the power supplied by the generator at the moment of island formation. Consequently, the generator will under-speed or over-speed until it has responded to the change in demand. The threshold setting of a ROCOF relay should be higher than any likely system wide transient, such as because of the loss of a bulk generator. Typical settings for ROCOF relays are ± 0.125 Hz/s in the UK and continental networks, or ± 0.5 Hz/s in the Republic of Ireland which is a smaller system [6]. In much the same way as vector shift, ROCOF assumes a generator that will experience a speed change when load is increased/decreased; this may not be applicable to inverter-based generation.

3.2 Limitations of traditional methods

ROCOF and VS methods are prone to undesired operation, or nuisance tripping [7]. This has been a known problem since the inception of such technologies, but was not a problem on grids with little installed capacity of embedded generation. This is no longer the paradigm on many grids [3, 8–14]. In the UK, wind and embedded generation infeeds of 22% have been seen [15, 16], while Ireland regularly operates with 50% of demand supplied by

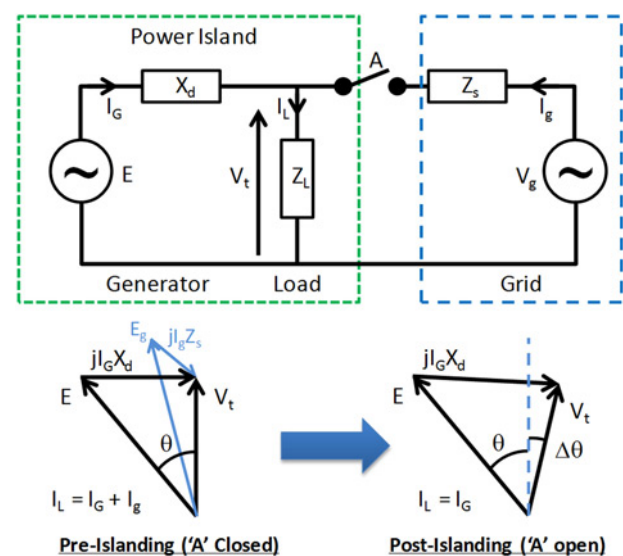

Fig. 2 Voltage phase angle 'shifts' after island formation because of load imbalance

'non-synchronous generation', the majority of which is wind generation [1]. Under such operating conditions, nuisance tripping of islanding detection can lead to a serious shortfall of generation. Furthermore, there is the potential for 'cascade tripping' [17], which would require widespread load shedding to prevent system collapse.

ROCOF relays are only effective when there is clear demarcation between frequency deviations caused by loss of bulk generation and the relay setting. In Ireland, transients of 1 Hz/s are anticipated in the future [6] thus ROCOF relays need to be desensitised, significantly reducing the relay's ability to detect a genuine loss-of-mains event. VS is less effected by system wide frequency, but by its nature, local transient events can cause VS to occur. It is often regarded by practitioners in the field as a more stable alternative to ROCOF by embedded generator owners, but this stability is at the expense of a wide non-detection zone (NDZ) which requires quite a large islanded load imbalance to operate. VS as a loss-of-mains method is put under scrutiny in [7]. With a large NDZ, out-of-phase reclosure and unintentional island operation become a real possibility.

3.3 Alternative methods

It is not possible to adequately differentiate loss-of-mains events from widespread system disturbances using traditional loss-of-mains techniques which rely only on measurement at the point of connection of the embedded generator to the grid. A variety of alternative methods for loss-of-mains protection have been proposed. One proposed technique uses an inter-tripping method to signal to the generator when it has lost connectivity with the utility [18]. Such a method is impractical since it relies on every possible point of disconnection having signalling capability. Complimentary ROCOF proposes sending an inhibit signal to generator protection in the event a ROCOF event is seen at a major transmission substation [8]. This method is practical, but still suffers from variability in the performance of ROCOF algorithms [17]. Other methods focus on detecting changes in power quality, usually voltage harmonic content, after islanding has occurred [11, 19, 20]. Such methods favour inverted-based generation, such as PV arrays, and may not be applicable more generally. In addition, they operate complex mathematical algorithms that may prove difficult to tune by the generator owners. 'Active' methods exist which inject pilot tones, impedance monitoring tones, harmonics, negative-sequence current [21, 22] or power perturbations into the system to assess islanding [3], but these systems have not found favour with utilities. Other more radical solutions to the loss-of-mains problem have also been proposed [23, 24], but would require significant development before universal acceptance.

The authors propose a method of loss-of-mains detection that is practical, feasible and immune to system wide disturbances by reconsidering the loss-of-mains protection problem as a 'sync-check' relay. PMU technology allows the phase of generators to be continuously monitored with respect to a secure point on the utility infrastructure. If synchronism is lost, loss-of-mains is identified. The authors proposed a simple form of the technique described in this paper in [14]. A similar simple method is described for inverter connected PV generation in [11], but the authors' current design is applicable to all embedded generation.

4 Synchrophasor loss-of-mains detector

The authors propose a new form of loss-of-mains protection based on PMU technology. The solution considers an islanding event to be a 'loss-of-synchronism'. PMUs are used to compare the frequency and phase angle of the embedded generation with a synchrophasor derived from a secure point on the utility infrastructure (e.g. a major substation), see Fig. 3. If the frequency of the generator is the same as the utility grid, then the phase angle of the generator will track the phase angle of the utility within a certain range of variation. If the generator becomes disconnected from the grid, the phase angle of the generator will, in all probability, diverge from that of the utility grid. The system can be thought of as a wide area 'sync-check' relay.

In normal operation, the phase angle of the generator will vary against the reference phasor because of fluctuations in system demand, changes in the configuration of the transmission network and local site loads. It is necessary that the loss-of-mains system is able to determine the typical phase variation at the embedded generator site, and respond only when anomalous behaviour is identified. Thus, a prototype detector has been designed as represented by the schematic diagram in Fig. 4.

The principle of operation is as follows. The detector acquires the phase angle of the generator it is protection, and from a reference site via synchrophasor. The reference synchrophasor arrives via Internet telecoms and therefore experiences a non-deterministic delay, usually <100 ms.

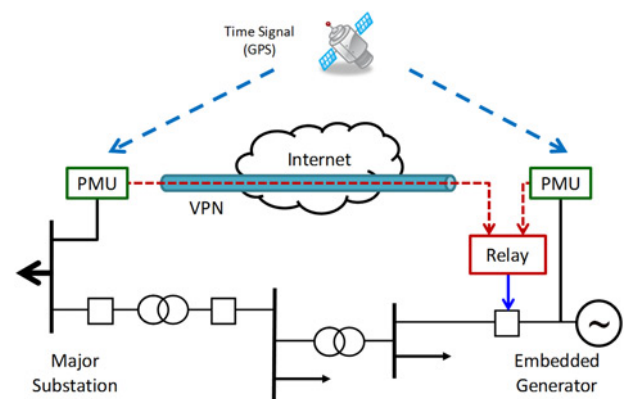

Fig. 3 Proposed islanding detection technique using synchrophasors to provide 'continuous sync check'

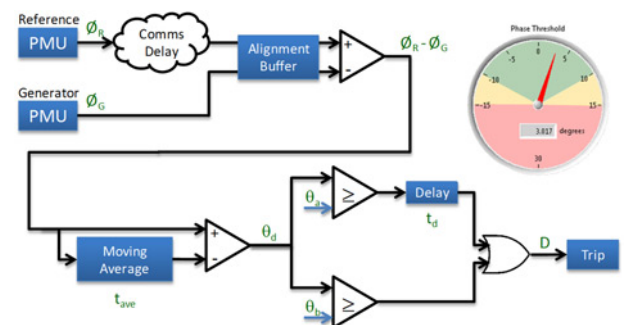

Fig. 4 Prototype synchrophasor islanding detector schematic and user interface

Green indicates that the system is health, yellow is a delayed trip and red is an instantaneous trip

An alignment buffer is used to ensure the algorithm is fed the most current synchrophasors with matching timestamps. The alignment buffer operates by feeding both the reference synchrophasor and generator synchrophasor into an array indexed by the timestamp of the synchrophasor. This array of synchronised data is then employed within the detector algorithm. The phase of the generator, θ_G , with respect to the reference, θ_R , is calculated, and a moving average of period 1 h, t_{ave} , normalises the phase difference of the generator, θ_d , about 0° . The period of the moving average is somewhat arbitrary, but should be several orders of magnitude more than the islanding detection time (seconds) and of the same timescale as normal network load variation (i.e. several thousand seconds). The relay outputs a binary trip signal, D, if either of two events happens. If the generator phase difference, θ_d , exceeds the threshold for delayed trip, θ_a , for more than the delay time, t_d , then the relay trips. If θ_d exceeds the threshold θ_b then the relay responds by tripping immediately. This allows for the generator to have a temporary phase excursion following a system wide transient provided that it is brief in duration and not excessively large. The rationale for this approach is explained in the next section in which the authors experimentally evaluate suitable detector thresholds for θ_a and θ_b .

4.1 Advantages

The advantage of the authors' method is in the simplicity of the principle of operation. Rather than trying to identify loss-of-mains by an indirect method, the synchronism of the embedded generator is continuously monitored. If synchronism is lost, then loss-of-mains is identified. There are several technical advantages.

4.1.1 Non-detection zone: Owing to the principle of operation, the detector will only indicate a fault whenever the embedded generator is out-of-phase with the utility reference signal. Consider, if an island were to form with almost perfectly balanced generation and load, the phase of the islanded generator may remain within the threshold $\pm\theta_a$. This would not cause a hazard from the perspective of out-of-phase reclosure, since the islanded generator is operating in phase with the utility supply. The detector will always signal a trip condition whenever the generator phase angle with respect to the utility reference is out-of-phase by more than the threshold setting. In practical terms, even for an island with a very close frequency match to that of the utility, the time taken for islanding to be detected will be a matter of seconds. A frequency mismatch of 0.125 Hz (based on current UK ROCOF setting) would be detected in 330 ms, while a mismatch as low as 20 mHz is detected in 2 s.

It can be said that in terms of out-of-phase reclosure, there is a zero non-detection zone. If ROCOF and VS fail to detect a transient at the moment of island formation, an unintentional island may operate indefinitely. Using the proposed method, if the generator operates out-of-phase with the utility supply by more than the configured phase threshold, a trip condition is always identified. In terms of unintentional islanded operation, a non-detection zone exists but only as a time limited quantity. In practical terms, the synchrophasor method will detect islanding in a matter of seconds, whereas conventional methods might never detect that an unintentional island has formed.

4.1.2 Detection time: The principle of the detector is such that it monitors the synchronism of the embedded generator with respect to the utility. If the phase-drift is less than the threshold $\pm\theta_a$, then it is safe to reclose. The authors have previously shown an out-of-phase reclose of $\pm 60^\circ$ is within the transient torque and current limits for a synchronous machine [25, 26], but would not recommend such a large out-of-phase reclosure as common practice. A much smaller threshold is recommended in Section 5. Detection time for out-of-phase reclosure is thus effectively zero seconds, since as the authors show in [25, 26], an embedded generator could be reclosed without damage even after the synchrophasor loss-of-mains has indicated an island has formed.

As described previously, it is extremely unlikely that a power islanded would remain in synchronism with the main utility perpetually. Realistically, even in an almost perfectly load/generation matched islanded, phase will drift sufficiently in a matter of a few seconds.

4.1.3 Nuisance tripping: Nuisance tripping is eliminated with the proposed method. In the event of a telecommunication failure, the relay can revert to conventional ROCOF or VS operation until such times as the reference synchrophasor is restored.

5 Phase variation

It is necessary to determine the phase variation thresholds for the loss-of-mains protection. This must consider both the day-to-day phase variation arising from normal system operation (θ_a), and also the effects of major system disturbances (θ_b). The authors operate an extensive network of PMUs across Great Britain and Ireland, allowing two power systems with different dynamic behaviour to be studied. The PMUs are of the authors' own design, and some commercially available units. The own design units are a low cost design optimised for distribution network applications such as loss-of-mains protection. Since it is required to estimate phase angles during transient, or dynamic, events it is necessary to comply with the IEEE Std. C37.118.1-2011 which sets out compliance tests for PMUs during dynamic conditions. The authors achieve this with their design with the aid of a curve fitting algorithm from the LabVIEW signal analysis toolbox, as described in [27]. If commercialised these could achieve a similar price point to traditional loss-of-mains relays. Over the period of operation, several noteworthy transients have been observed. The most extreme are discussed here.

5.1 Phase variation during normal system operation

An experiment was carried out to assess the phase variation between an embedded generator and a substation during normal system operation. Two PMUs were installed on the island of Ireland on a section of network regarded as weakly interconnected near Letterkenny, County Donegal, Fig. 5. A table of parameters for the system is given in Appendix. The PMU representing the utility reference site was installed at Letterkenny Institute of Technology (LYIT), as the campus is electrically close to a nearby 110 kV substation and is supplied via a dedicated 38 kV substation. The area of this study includes a significant rural element of network where there is considerable variation in renewable generation output.

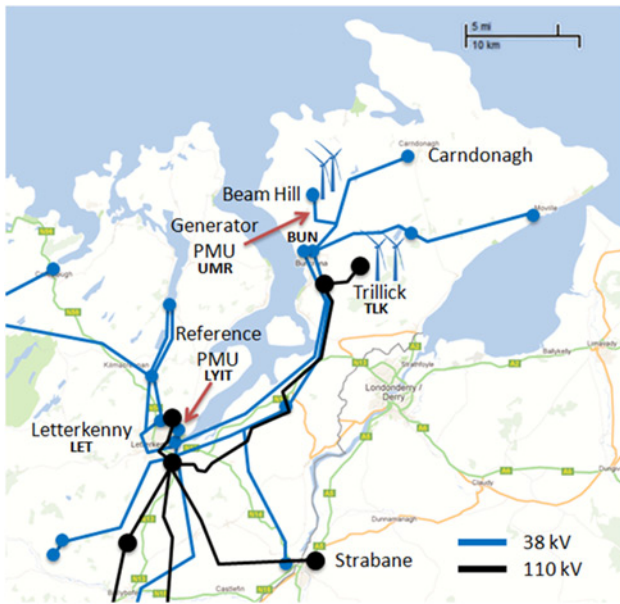

Fig. 5 Location map and network schematic for the utility reference PMU and the generator PMU showing 38 and 110 kV network

The PMU representing the generator site is connected adjacent to Beam Hill wind farm (installed capacity 14 MW) on the Inishowen peninsula. Four wind farms totalling 131 MW capacity are installed on the peninsula. This power is exported via 38 and 110 kV lines.

Phase data were collected at the two sites over a period of 3 months. The phase variation between the generator site and reference site is expressed as a probability density function (PDF), Fig. 6. A PDF is used since there are 4.3 million phasors recorded daily, thus making it necessary to represent them statistically. The daily phase variation is plotted for each day in the week that featured the largest single daily variation. Each phase angle sample recorded throughout the day has been assigned to a bin of width 0.05° , thus the PDF represents the probability that a phase angle sample chosen at random lies in that bin. Several days of data over the course of the study are superimposed and the maximum highlighted by the bold line. This indicates that over the duration of the study, the daily phase

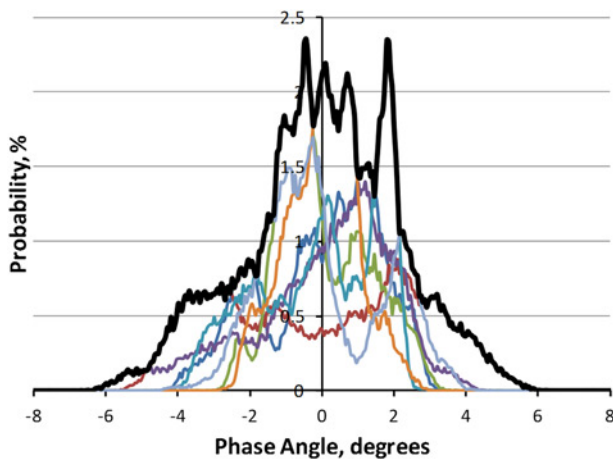

Fig. 6 PDF featuring data over the course of the study. Maximum values are highlighted by heavy black line

variation during normal system operation was less than $\pm 7^\circ$. The detector compares with the average over the previous hour, so will experience less variation.

5.2 Phase variation during major system disturbances

The authors have captured a number of major system disturbances on both the Great Britain and Ireland power systems. Of particular interest to this study are events leading to extreme frequency excursions and phase fluctuations. These are usually associated with the loss of a large infeed, such as a bulk generator or system interconnector. Two such events, caused by the loss of the DC interconnector between Great Britain and France, occurred in September 2012. The interconnector involved is labelled 'A' in Fig. 7. A third event, caused by the loss of a DC interconnector between Great Britain and Ireland, labelled 'B' in Fig. 7, occurred in April 2013.

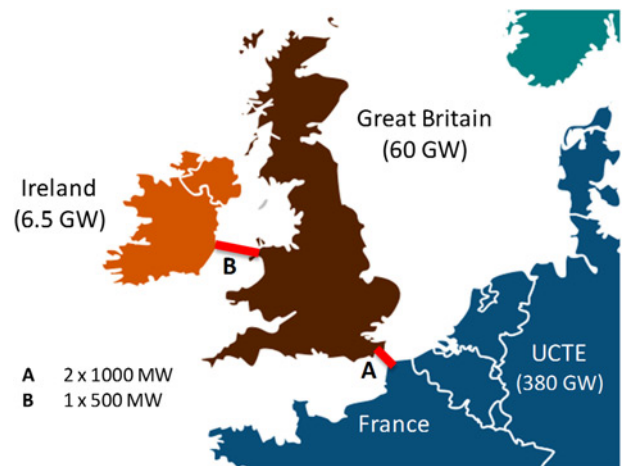

Fig. 7 Location of interconnectors involved in this study

UCTE is the union for the coordination of the transmission of electricity, representing much of continental Europe

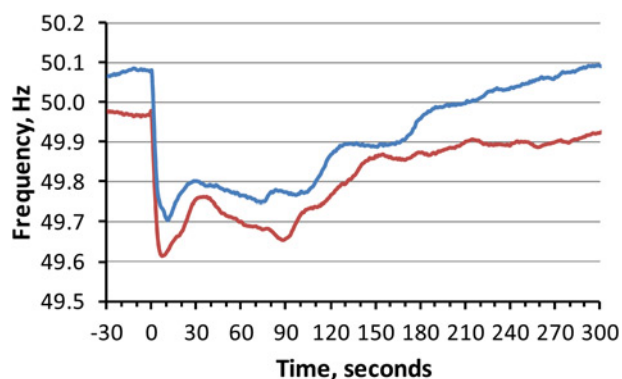

Fig. 8 Frequency transient on GB power system following loss of 1 GW of DC interconnector supply, 28 September 2012 (red), 30 September 2012 (blue)

5.2.1 September 28/30 2012 – GB-France DC interconnector: On 28 September 2012, 1 GW of infeed to the Great Britain power system was lost when one half of the 2 GW ‘HVDC Cross-Channel Interconnector’ between Great Britain (GB) and France disconnected. This sudden loss of supply caused a large frequency excursion on the GB power system, leading to fluctuations in phase angle across the transmission network as spinning reserve picked up the generation shortfall. A similar event occurred on 30 September 2012 when the HVDC interconnector again disconnected with the loss of 1 GW infeed. The repetition of this event makes it possible to determine how such a large generation loss would affect the phase variation in the proposed loss-of-mains protection scheme. The frequency deviations because of the 1 GW losses are shown in Fig. 8.

In the 10 s after the loss, the frequency of the system fell by approximately 0.4 Hz. The PMU data indicates a peak df/dt of -0.6 Hz/s. However, ROCOF estimates are subjective since the period for dt is not standardised and filtering algorithms vary by manufacturer. Utility owned instruments estimate the ROCOF event as -0.13 Hz/s. This is in excess of the recommended UK relay setting of -0.125 Hz/s. Utilities have reported that this frequency transient caused many embedded generators to be disconnected by their islanding detection systems. It is estimated by some utilities that up to 80 MW of generation was lost in the south of England. This exacerbated the original generation loss (by 8%), making recovery of the system frequency more difficult. It

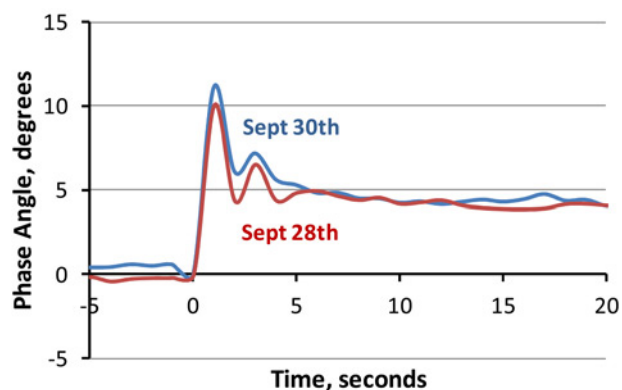

Fig. 9 Phase angle variation between embedded generator sites after 1 GW of supply lost on main grid

would be beneficial if embedded generation was to remain connected during such system wide disturbances.

Fig. 9 shows the phase angle between two points on the Great Britain system at the moment of the fault. One point is a main substation and the second is on the distribution network. The two sites are at the far ends of the GB electrical system, one in southern England the other in northern Scotland, a distance of approximately 1000 km apart. On both occasions, there is a step change in phase angle at the moment of the system transient. Each time this is approximately $+10^\circ$ from the previous nominal phase angle between the sites. After 6–8 s, the phase angle settles to approximately $+4^\circ$ of its pre-transient value. The phase angle is seen to ‘ring’ immediately after the fault, because of generation shortfall being picked up by spinning reserve throughout the network. This data reveals that the detector must tolerate momentary phase deviations as large as $\pm 10^\circ$. However, use of electrically closer reference points may lead to a lesser phase deviation.

5.3 Phase threshold recommendation

Based on the results from studying normal system variation, a threshold of $\pm 7^\circ$ was found to be suitable for a weak network with high wind penetrations. This ‘healthy’ variation threshold will be site specific and could be monitored and tuned by the relay itself upon installation.

What has been highly useful is the capture of two major system transients, of the same type, a period of 2 days apart. This has demonstrated that the sudden loss of 1 GW of bulk generation on a major power system causes, firstly, a peak phase deviation of $+10^\circ$, which then settles at a new angle of approximately $+4^\circ$. Since the sites being monitored did not island, this reveals that the threshold for islanding detection must be as wide as at least $\pm 10^\circ$.

The authors propose a relay that operates with two thresholds. The transient events have shown that during system transients, large phase deviations can occur for a moment. However, the generator returns to normal behaviour thereafter. Thus, the first threshold will trigger a time delayed relay actuation, and the second threshold an immediate actuation. If the generator phase angle hits the first threshold, θ_a , the phase angle must return to within the healthy region before the time delay elapses. If the generator phase angle transgresses the second threshold, θ_b , it is immediately disconnected as a precaution against damage. The values for θ_b and t_d can be adjusted depending on fault ride through requirements.

The first threshold represents normal system phase variation. If the generator strays outside of this threshold, the relay activates after a time delay. This takes into account that the generator may briefly fall outside of normal phase variation after a major system transient, providing fault ride through as described in [6]. At the second threshold, the relay activates instantaneously, providing protection against out of synchronism reclosure. The authors recommend a time delay threshold of $\pm 10^\circ$, and an instantaneous threshold of $\pm 15^\circ$.

6 Prototype performance

The detector described in Section 4 has been prototyped in Labview. A user interface has been designed with the aim of being intuitive for generator operators, Fig. 4, which is considered an important aspect in the adoption of this new

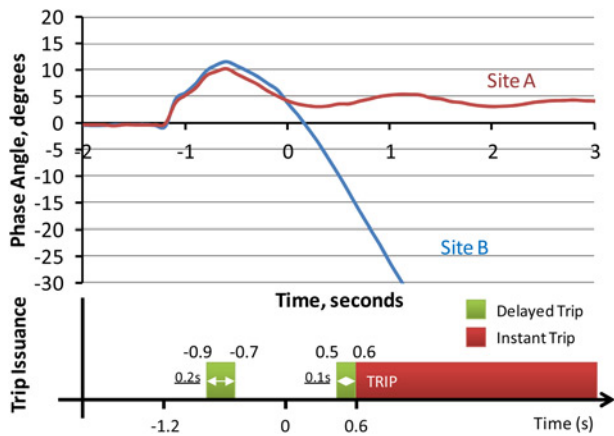

Fig. 10 Phase of two sites protected by prototype loss-of-mains detector in response to transient event of 28 Sept

'Site B' experiences islanding, 'Site A' does not
Pre-islanding ($t=0$ s), a delayed trip is correctly cancelled, post-islanding a trip condition is indicated at $t=0.6$ s

method. The synchroscope shows the phase angle of the generator with respect to the reference, and an enlarged colour coded gauge indicates the trip thresholds.

The detector's response has been verified through a variety of simulated test scenarios and by application of recorded historical transients. In this section, the operation of the detector is assessed by its response to the frequency transient event on the GB system from 28 September 2012, Fig. 8. Three sites are involved, 'Site A', 'Site B' and 'reference'. Sites A and B are electrically close, while the reference is a main substation some distance away. Fig. 10 describes the phase variation at Sites A and B with respect to the reference. Site A did not island and the phase shift is seen to oscillate and then settle when the transient occurs. 'Site B', however, islanded at $t=0$ s in response to the transient event.

The pre-islanding transient begins at $t=-1.2$ s. The phase of both Sites A and B quickly diverge from the reference site. After 0.3 s, the detector starts the delayed trip timer, but resets it 0.2 s later as the phase returns to the healthy threshold. This is correct operation since neither site is islanded at this time. At $t=0$ s, 'Site B' becomes islanded. Its phase angle diverges quickly, passing -10° after 0.5 s (starting the timer), then passing -15° after 0.6 s, causing the islanding detection relay to trip. This has been annotated on Fig. 10, using green to identify delayed trip signal (i.e. it must be valid for 0.5 s before actuating the relay) and red to identify an instantaneous trip condition. If the relay had actuated at -0.9 s, it would have acted before islanding had actually occurred. The use of the instantaneous trip threshold means that the relay trips at 0.6 s, which is quicker than using only the threshold with trip delay (activated at 0.5 s + future 0.5 s before issuing the trip command).

The detector confirmed islanding 0.6 s after the potential for out of synchronism reclosure occurred, and indicated that Site B should be considered islanded when it was just 20° out-of-phase with Site A. This is a good response given the benefits that wide area continuous sync-check affords.

Crucially, the initial transient was the same at both Sites A and B. However, the detector has been able to correctly identify the islanding of Site B while discrimination the transient at Site A as a non-islanding event, thereby avoiding nuisance tripping.

7 Conclusions

This paper has presented the islanding problem and noted deficiencies with existing methods of islanding detection for networks featuring high penetrations of embedded generation, including renewable generation. A new type of islanding detector has been proposed that utilises synchrophasor measurements to make the islanding determination based on the phase angle of the embedded generator with respect to a reference site. This method is performing a sync-check over a wide area to establish if the embedded generator has a connection to the utility. With this technique nuisance tripping is virtually eliminated and it has a zero non-detection zone.

Threshold settings have been recommended for the detector based on experimental observations. This was done under both normal system operation, and when the system experienced significant system wide transient events. The authors have shown that, normally, a generator will not vary, typically, beyond $\pm 7^\circ$ even on a weakly interconnected section of network. Transient events can cause momentary phase variations of up to $\pm 10^\circ$, even if the transient is initiated at a distant point on the transmission system. This leads the authors to make conservative recommendations for the detector thresholds of $\pm 10^\circ$ for normal operation, with excursions up to $\pm 15^\circ$ tolerated for short periods of time.

The detector has been implemented in Labview, and designed with an intuitive user interface. The detector has been shown to respond correctly to a system-wide transient, both disconnecting an islanded generator site, and leaving a non-islanded generator site connected. The authors are continuing to pursue development of the technology through an ongoing field trial with Scottish & Southern Energy Ltd., and with consideration of the output power of the embedded generator and the consequent effect on phase angle.

8 Acknowledgments

The authors wish to acknowledge the financial support and technical assistance of Scottish and Southern Energy Limited. This work was supported by a Charles Parsons Energy Research Award, which is funded by the Science Foundation Ireland (SFI), award (06/CP/E002). The authors also thank Letterkenny Institute of Technology for hosting PMU devices during this study.

9 References

- 1 Eirgrid: 'Wind generation & system demand data' (Eirgrid Plc, Dublin, Ireland, 2013), available at: <http://www.eirgrid.com>
- 2 Ding, X., Crossley, P.A.: 'Islanding detection for distributed generation'. IEEE Power Tech, 2005, Russia, 27–30 June 2005, pp. 1–4
- 3 O'Kane, P., Fox, B.: 'Loss of mains detection for embedded generation by system impedance monitoring'. Sixth Int. Conf. on Developments in Power System Protection, (Conf. Publ. No. 434), 25–27 March 1997, pp. 95–98
- 4 Engineering Recommendation G59/3 – Recommendations for the Connection of Generating Plant to the Distribution Systems of Licensed Distribution Network Operators, ENA, 1 September 2013
- 5 IEEE Guide for Design, Operation, and Integration of Distributed Resource Island Systems with Electric Power Systems'. IEEE Std 1547.4-2011, 20 July 2011, pp. 1–54
- 6 Eirgrid: 'DS3: rate of change of frequency (RoCoF) workstream' (Eirgrid Plc, Dublin, Ireland, 2011)
- 7 ETR 139: 'Engineering Technical Report 139: Recommendations of Settings for Loss of Mains Protection Relays'. Energy Networks Association, November 2009

- 8 Bright, C.G.: 'COROCOF: comparison of rate of change of frequency protection. A solution to the detection of loss of mains'. Seventh Int. Conf. on Developments in Power System Protection, 2001, (IEE), 2001, pp. 70–73
- 9 Dola, H.M., Chowdhury, B.H.: 'Intentional islanding and adaptive load shedding to avoid cascading outages'. Power Engineering Society General Meeting, 2006
- 10 Mills-Price, M., Scharf, M., Hummel, S., *et al.*: 'Solar generation control with time-synchronized phasors'. 64th Annual Conf. for Protective Relay Engineers, 2011, 11–14 April 2011, pp. 160–167
- 11 SEL Inc.: 'Smart anti-Islanding using synchrophasor measurements'. Case study application note, 2010
- 12 Laverty, D.M., Morrow, D.J., Best, R., Cregan, M.: 'Anti-islanding detection using synchrophasors and Internet Protocol telecommunications'. 2011 Second IEEE PES Int. Conf. and Exhibition on Innovative Smart Grid Technologies (ISGT Europe), 5–7 December 2011, pp. 1–5
- 13 Lund, P.: 'Loss of distributed generation by grid faults – a Danish case study'. Second Int. Conf. on Critical Infrastructures CRIS 2004: Securing Critical Infrastructures, Grenoble, France, October 2004
- 14 Laverty, D.M., Morrow, D.J., Best, R.J., Crossley, P.A.: 'Differential ROCOF relay for loss-of-mains protection of renewable generation using phasor measurement over internet protocol'. Integration of Wide-Scale Renewable Resources Into the Power Delivery System, 2009 CIGRE/IEEE PES Joint Symposium, 29–31 July 2009, p. 1
- 15 'Wind Energy in the UK: State of the Industry Report 2012', Renewables UK, London, UK, October 2012 <http://www.renewableuk.com/en/publications/reports.cfm/SOI2012>
- 16 Balancing Mechanism Reporting System, ELEXON Limited, available at: www.bmreports.com, January 2014
- 17 Ten, C.F., Crossley, P.A.: 'Evaluation of Rocof relay performances on networks with distributed generation'. IET 9th Int. Conf. on Developments in Power System Protection, 2008 (DPSP 2008), 17–20 March 2008, pp. 523–528
- 18 Ding, L., Pan, Z., Cong, W., Pang, J.: 'An integrated automatic control system for distributed generation hierarchical Islanding'. Int. Conf. on Power System Technology, 2006. PowerCon 2006, 22–26 October 2006, pp. 1–6
- 19 Kim, J.-H., Kim, J.-G., Ji, Y.-H., Jung, Y.-C., Won, C.-Y.: 'An islanding detection method for a grid-connected system based on the goertzel algorithm', *IEEE Trans. Power Electron.*, 2011, **26**, (4), pp. 1049–1055
- 20 Yu, B., Jung, Y., So, J., Hwang, H., Yu, G.: 'A robust anti-islanding method for grid-connected photovoltaic inverter'. Fourth World Conf. on Photovoltaic Energy Conversion, Conf. Record of the 2006 IEEE, May 2006, vol. 2, pp. 2242–2245
- 21 Karimi, H., Yazdani, A., Iravani, R.: 'Negative-sequence current injection for fast islanding detection of a distributed resource unit', *IEEE Trans. Power Electron.*, 2008, **23**, (1), pp. 298–307
- 22 Hernandez-Gonzalez, G., Iravani, R.: 'Current injection for active islanding detection of electronically-interfaced distributed resources', *IEEE Trans. Power Deliv.*, 2006, **21**, (3), pp. 1698–1705
- 23 Best, R.J., Morrow, D.J.: 'Synchronous islanded operation of a diesel generator', *IEEE Trans. Power Syst.*, 2007, **22**, (4), pp. 2170–2176
- 24 Best, R.J., Morrow, D.J., Laverty, D.M., Crossley, P.A.: 'Synchrophasor broadcast over internet protocol for distributed generator synchronization', *IEEE Trans. Power Deliv.*, 2010, **25**, (4), pp. 2835–2841
- 25 Best, R.J., Morrow, D.J., Crossley, P.A.: 'Effect of loading, voltage difference and phase angle on the synchronisation of a small alternator', *IET Electr. Power Appl.*, 2009, **3**, (6), pp. 531–542
- 26 Best, R.J., Morrow, D.J., Crossley, P.A.: 'Current transients in the small salient-pole alternator caused by sudden short-circuit and synchronisation events', *IET Electr. Power Appl.*, 2010, **4**, (9), pp. 687–700
- 27 Laverty, D.M., Best, R.J., Brogan, P., Al Khatib, I., Vanfretti, L., Morrow, D.J.: 'The OpenPMU platform for open-source phasor measurements', *IEEE Trans. Instrum. Meas.*, 2013, **62**, (4), pp. 701–709

10 Appendix

Table of parameters for network shown in Fig. 5 (see Table 1).

Table 1 Parameters for network in Fig. 5

Line	Type	R, Ω	X, Ω	Rating, MVA	
LET-TLK	110 kV single	6.53	14.4	101	
LET-TLK	38 kV double	10.325	16.8	20	
TLK-BUN	38 kV double	0.59	0.96	20	
BUN-UMR	10 kV single	4.21	2.82	2	
Transformer	Quantity	Rating	$X, \%$	X/R	
LET	110/38 kV	3	60 MVA	15	34
TLK	110/38 kV	1	45 MVA	13.5	25
LET-LYIT	38/10 kV	2	5 MVA	7.5	10
BUN	38/10 kV	2	5 MVA	7.5	10
LYIT	10/0.4 kV	1	1 MVA	5	8
UMR	10/0.4 kV	1	50 kVA	2.5	2
Wind gen	MW				
LET	38 kV	42			
TLK	110 kV	55			
BUN	38 kV	34			
Load	Bus	Winter peak		Summer min	
		MW	MVA _r	MW	MVA _r
LET	38 kV	62.6	17.52	16.45	4
LYIT A	10 kV	3.8	0.92	0.85	0.2
LYIT B	400 V	0.2	0.05	0.2	0.05
BUN A	38 kV	16.08	2.81	6.08	1.9
BUN B	10 kV	2.81	0.88	1.06	0.33
UMR A	10 kV	0.38	0.12	0.15	0.05
UMR B	400 V	0.02	0	0	0