



**QUEEN'S
UNIVERSITY
BELFAST**

Transient Model of Dual Loop Waste Heat Recovery System

Chowdhury, J. I., Nguyen, B. K., & Thornhill, D. (2016). Transient Model of Dual Loop Waste Heat Recovery System. In *Book of Abstracts of the 3rd Annual Engine ORC Consortium Workshop for the Automotive and Stationary Engine Industries*

Published in:

Book of Abstracts of the 3rd Annual Engine ORC Consortium Workshop for the Automotive and Stationary Engine Industries

Document Version:

Peer reviewed version

Queen's University Belfast - Research Portal:

[Link to publication record in Queen's University Belfast Research Portal](#)

Publisher rights

Copyright 2016 the authors.

General rights

Copyright for the publications made accessible via the Queen's University Belfast Research Portal is retained by the author(s) and / or other copyright owners and it is a condition of accessing these publications that users recognise and abide by the legal requirements associated with these rights.

Take down policy

The Research Portal is Queen's institutional repository that provides access to Queen's research output. Every effort has been made to ensure that content in the Research Portal does not infringe any person's rights, or applicable UK laws. If you discover content in the Research Portal that you believe breaches copyright or violates any law, please contact openaccess@qub.ac.uk.

Open Access

This research has been made openly available by Queen's academics and its Open Research team. We would love to hear how access to this research benefits you. – Share your feedback with us: <http://go.qub.ac.uk/oa-feedback>

TRANSIENT MODEL OF DUAL LOOP WASTE HEAT RECOVERY SYSTEM

Jahedul I. Chowdhury*, Bao K. Nguyen and David Thornhill

School of Mechanical and Aerospace Engineering, Queen's University Belfast
Stranmillis road, BT9 5AH, Belfast
United Kingdom
e-mail:jchowdhury01@qub.ac.uk
Web page: www.qub.ac.uk

Highlights: This paper presents a conceptual dual loop waste heat recovery system to reduce the disturbance of the high-transient heat sources from an internal combustion engine and investigates a dynamic model of the waste heat recovery system at supercritical condition.

Key words: dynamic evaporator, finite volume method, organic Rankine cycle, supercritical condition, waste heat recovery

EXTENDED ABSTRACT

Introduction

Waste Heat Recovery (WHR) from an Internal Combustion (IC) engine using supercritical Organic Rankine Cycle (ORC) has been an interesting research area in recent years due to the higher thermal efficiency of the cycle and lower fuel energy losses to the environment [1]. Since the heat source from IC engines are highly transient in mass flow rate and temperature, the well-known Finite Volume (FV) model of the evaporator in steady state condition [2] cannot be used to predict the thermal inertia of the cycle when it is subjected to transient heat sources in the WHR system. In this paper, a dynamic FV model of the evaporator has been developed and integrated with other components in the ORC-WHR system. The system performance of the transient heat source is also investigated in this research.

Methodology

The conceptual waste heat recovery system shown in Fig. 1 includes two loops: the secondary fluid loop or heat collection unit and an energy conversion unit or the ORC. In this schematic diagram, the heat from an internal combustion engine's exhaust and coolant is initially transferred to the carrier fluid, i.e. thermal oil or water. The hot carrier fluid from the secondary fluid loop is then passed through the evaporator of the ORC. The liquid organic fluid is pumped to the evaporator where it is heated and vaporized by the hot carrier fluid and expanded in the expander. Since the evaporator is the main contributor to the thermal inertia of the WHR system, the dynamic model of the evaporator is developed using the finite volume method and the mass and energy conservation equations of the evaporator model are solved numerically in this research.

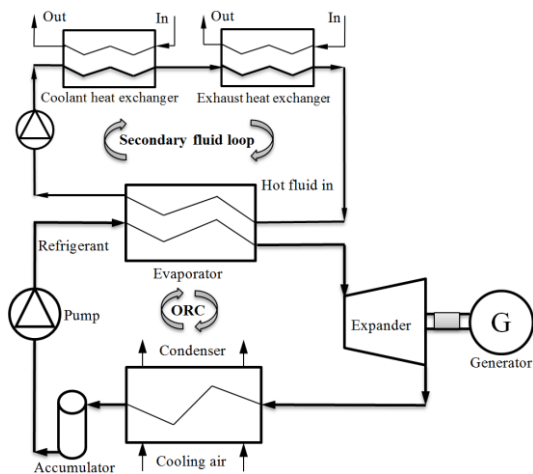

Fig. 1. Conceptual dual loop waste heat recovery system.

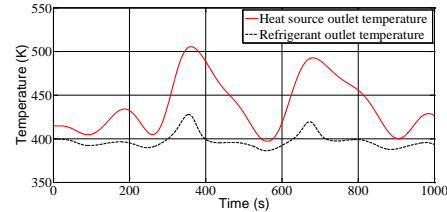

Fig.2. Outlet temperatures of dynamic evaporator model.

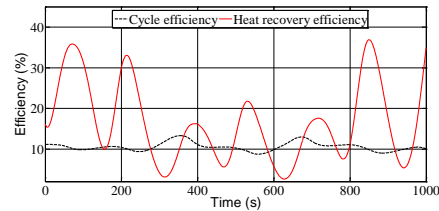

Fig.3. ORC-WHR efficiency for the simulation of random heat source in dynamic scenario.

Results

A random heat source in terms of mass flow rate (from 0.05 kg/s to 0.20 kg/s) and temperature (from 412 K to 523 K) is used for the investigation of the waste heat recovery system at supercritical condition in this paper. The working fluid of the ORC used in this simulation is R134a, which is readily available, widely used in commercial purposes and has a high auto-ignition temperature. A random profile of the refrigerant mass flow rate (from 0.02 kg/s to 0.12 kg/s) is used in this simulation. The simulation outcomes are shown in Figs. 2-3. Since the simulation was carried out with the random inputs and without a control measure, the outputs of the evaporator model and the efficiency of the ORC and WHR system varied according to the combination of the model inputs. The benefit of the supercritical conditions is that a higher thermal efficiency can be obtained at the expense of a lower heat recovery. However, an optimization of these two efficiencies can derive the most beneficial operating condition of the WHR system.

Conclusions

The developed model is able to depict the performance of the ORC-WHR system dealing with the variable heat sources at a supercritical pressure. The concept of dual loop WHR system and the dynamic model of the supercritical ORC investigated in this research have potential to reduce the highly transient heat input to the ORC-WHR used in automobile applications.

References

- [1] S. Glover, R. Douglas, M. De Rosa, X. Zhang and L. Glover, "Simulation of a multiple heat source supercritical ORC (organic rankine cycle) for vehicle waste heat recovery", Energy, Vol. 93, pp. 1568-1580, (2015).
- [2] S. Karellas, A. Schuster and A. Leontaritis, "Influence of supercritical ORC parameters on plate heat exchanger design", Appl. Therm. Eng., Vol. 33-34, pp. 70-76. (2012).

Background of the research and development team

Jahedul Islam Chowdhury received the MSc thermal power and fluid engineering from the University of Manchester, UK in 2013. He is currently studying final year of PhD on “Modelling and Control of Waste Heat Recovery System”. Chowdhury has been developed a novel fuzzy based evaporator model in the ORC-WHR system.

Dr. Bao Kha Nguyen is currently a lecturer at School of Mechanical and Aerospace Engineering, Queens University Belfast, UK, and a member of the Clean Energies cluster of the school. He has been the supervisor of the above-mentioned author since 2014. He has been involved in various aspects of control systems research and teaching for the past 15 years.