



**QUEEN'S
UNIVERSITY
BELFAST**

Sensitivity Analysis Of A Bottom Fixed Offshore Wind Turbine Using The Environmental Contour Method

Barreto, D., Moghtadaei, A., Karimirad, M., & Ortega, A. (2019). Sensitivity Analysis Of A Bottom Fixed Offshore Wind Turbine Using The Environmental Contour Method. In *Proceedings of the ASME 2019 38th International Conference on Ocean, Offshore and Arctic Engineering OMAE2019 June 9-14, 2019, Glasgow, Scotland: Structures, Safety, and Reliability* (Vol. 3). American Society of Mechanical Engineers (ASME).
<https://doi.org/10.1115/OMAE2019-95390>

Published in:

Proceedings of the ASME 2019 38th International Conference on Ocean, Offshore and Arctic Engineering OMAE2019 June 9-14, 2019, Glasgow, Scotland

Document Version:

Peer reviewed version

Queen's University Belfast - Research Portal:

[Link to publication record in Queen's University Belfast Research Portal](#)

Publisher rights

Copyright 2019 ASME. This work is made available online in accordance with the publisher's policies. Please refer to any applicable terms of use of the publisher.

General rights

Copyright for the publications made accessible via the Queen's University Belfast Research Portal is retained by the author(s) and / or other copyright owners and it is a condition of accessing these publications that users recognise and abide by the legal requirements associated with these rights.

Take down policy

The Research Portal is Queen's institutional repository that provides access to Queen's research output. Every effort has been made to ensure that content in the Research Portal does not infringe any person's rights, or applicable UK laws. If you discover content in the Research Portal that you believe breaches copyright or violates any law, please contact openaccess@qub.ac.uk.

Open Access

This research has been made openly available by Queen's academics and its Open Research team. We would love to hear how access to this research benefits you. – Share your feedback with us: <http://go.qub.ac.uk/oa-feedback>

OMAE2019-95390

SENSITIVITY ANALYSIS OF A BOTTOM FIXED OFFSHORE WIND TURBINE USING THE ENVIRONMENTAL CONTOUR METHOD

David Barreto

Facultad de Ingenieria Mecánica, Universidad
Nacional de Ingenieria
Lima, Perú
dbarretol@uni.pe

Madjid Karimirad

Civil Engineering, School of Natural and Built
Environment, Queen's University Belfast
Belfast, United Kingdom
madjid.karimirad@qub.ac.uk

Abdolmajid Moghtadaei

Civil Engineering, School of Natural and Built
Environment, Queen's University Belfast
Belfast, United Kingdom
amoghtadaei01@qub.ac.uk

Arturo Ortega

Institute for Energy Systems
School of Engineering
The University of Edinburgh
Edinburgh, UK
arturo.ortega@ed.ac.uk

ABSTRACT

In the field of stochastic dynamics of marine structures, environmental conditions play a vital role. Considering wind and waves as random processes, determining the environmental parameters which correspond to an annual exceedance probability for a certain structural concept is of vital importance for the respective assessment of the loads and their effects. The accuracy in predicting the conditions, especially those corresponding to the sea, is of a great relevance when a probabilistic design is performed in order to ensure the structural integrity of an offshore wind turbine. In particular, models are not always completely perfect and accurate data is not always available. The Environmental Contour Method (ECM), which is based on the IFORM methodology, is one of the most popular methods in the offshore industry when determining the environmental conditions, for a given annual exceedance probability, is required. The ECM allows analysing proper sea states for operational and extreme conditions with lower computational efforts than the most accurate method (Full Long-Term Analysis). In the present study, effects of progressive variations (uncertainties) of the sea states parameters (i.e. significant wave height, spectral peak period) on the dynamic response of a Monopile Wind Turbine (NREL 5MW) are analysed. Two operative conditions are considered: rated wind and cut-out wind speed. In each case, the 50-year environmental contour (EC) is plotted for a site located in the North Sea. Some sea states are selected from the EC (base cases) and then derived cases with percentage variations are generated. All the cases are simulated in FAST (NREL) and the standard deviations of the time series are compared with its respective values of

base cases. The results for the dynamic responses at mudline (e.g. overturning moments and shear forces) are presented as the most important parameters governing the design of the monopile. In this analysis, the wave height shows more influence on the response variation percentage than the peak period. This work shows the importance of accurately setting up the input parameters and their impact on the calculation of the dynamic responses.

Keywords: OWT, monopile, ECM, sensitivity analysis,

1. INTRODUCTION

For stochastic processes, the propagation of uncertainty is an important matter when getting a high confidence in the outputs predicted by models is required. The stochastic approach of dynamic analysis of structures is not indifferent to this issue. One popular tool for quantifying the impact of uncertainties is the sensitivity analysis.

The sensitivity analysis is a useful tool which seeks to explain how the uncertainty in the output of a model can be apportioned to sources of uncertainty in the input parameters of the model. The main purpose of the analysis is to comprehend the model and understand how uncertainty is propagated through it. Under this analysis, it is possible to address some important aspects e.g. which factors contribute most/less/nothing to the output uncertainty? How the output variance can be reduced to a desired level? [1]. There are basically two main approaches to perform a sensitivity analysis: the global approach and the local approach, whereas the first is focused in analyse the sensitivity in all the input variable domain, the second one emphasizes in analyse the sensitivity around a specific optimal point. The last approach requires that a good "baseline" or "nominal

point” is set with high accuracy. Both approaches involve many different methods, each one useful for a specific context e.g. OAT, Sobol method, Elementary Effects, etc [2]. Investigations in the field of wind energy related to sensitivity analysis have been done by Rinker et al. [3], Karimirad et al. [4], Horn et al. [5] and Robertson et al. [6], just to mention the most recent. Each work focused in different aspects of wind turbines to find out the influence of input parameters in the interested outputs.

This work is structured as follows: first, a brief presentation of the environmental contour method and main details of the NREL 5 MW Monopile Wind Turbine are presented. Then, the methodology used for the sensitivity analysis is described. Subsequently, the numerical analysis performed is presented. The results are analysed and discussed in a later section. Finally, the corresponding conclusions and future work are summarized.

2. THE ENVIRONMENTAL CONTOUR METHOD

The environmental contour method (ECM) is based in the IFORM approach (Inverse First Reliability Method). Under this procedure a sphere in a non-physical standardized normal space (U -space) can be generated for a given annual exceedance probability q or desired return period N . The radius of this sphere can be calculated with Eq. (1) as:

$$\beta = \Phi^{-1} \left(1 - \frac{1}{N * m_d} \right) = \Phi^{-1} \left(1 - \frac{q}{m_d} \right) \quad (1)$$

Where m_d is the expected number of d -hour sea states per year and Φ^{-1} denotes the operator of the inverse standard normal distribution. With the radius as known value, the three non-physical variables (U) can be determined using Eq. (2):

$$\beta^2 = U_{Uw}^2 + U_{Hs}^2 + U_{Tp}^2 \quad (2)$$

These non-physical variables are linked to the physical parameters through the Rosenblatt Transformation, Eqs. (3)-(5):

$$\Phi(U_{Uw}) = F(Uw) \quad (3)$$

$$\Phi(U_{Hs}) = F(Hs|Uw) \quad (4)$$

$$\Phi(U_{Tp}) = F(Tp|Uw, Hs) \quad (5)$$

F denotes the cumulative distribution function of the respective environmental parameters. With all the combinations of environmental parameters which satisfies Eqs. (3)-(5), it is possible to generate a contour surface (ECS) or contour line (ECL) which represents all the combinations of environmental conditions corresponding to the desired annual exceedance probability [7].

When a long-term extreme prediction is required, the ECM considers short-term simulations and the corresponding short-term extreme distribution in order to find the environmental condition with the largest value among all short-term extremes. The ECM initially considers on its analysis that the value of the short-term extreme distribution is the median (p -fractile of 50%) but, this is not totally accurate. In order to bypass this inaccuracy, it is needed to

use an empirical higher fractile to correct the predicted long-term value e.g. 90% is a usual p -fractile value.

Recent studies has shown that a modified version of the traditional ECM is required for offshore wind turbines (OWT) as the responses are not monotonically related to the main environmental parameters e.g. for wind speeds higher than cut-out wind speed, OWT remains parked to reduce loads. In this case, it is necessary to find an equivalent return period (N) to bypass the occurrence of change in the operational mode of the OWT. An iterative process, where inner contours are tested, is required to find this equivalent return period. After this process, the largest value of all the short-term extremes for all the environmental conditions on all the inner contours is then considered for the long-term response prediction [8].

The present work is not mainly focused on the sensitivity in the long-term extreme predicted responses, but rather on the impact in the short-term responses when uncertainties in the input parameters are introduced. Therefore, at this stage, the traditional ECM is considered suitable for the analysis. In further research, the use of the Modified ECM will be mandatory if the operational conditions need to be really reflected in the sensitivity analysis. Especially, for the cases where long-term extreme responses are the main focus.

3. THE NREL 5MW WIND TURBINE

For this analysis, the 5 MW NREL Wind Turbine supported by a monopile will be used [9]. This configuration has been widely studied and also has been validated with results from the OC3 project to verify the simulation capabilities of FAST [10]. The main dimensions of the wind turbine are presented in Fig. 1, as well as, the main characteristics are summarized in Table 1.

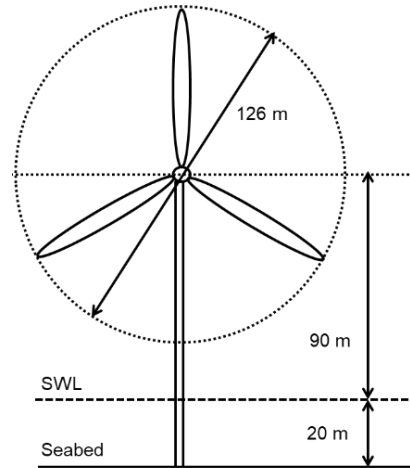

Figure 1. Main dimensions of the NREL 5 MW Wind Turbine.

4. SENSITIVITY ANALYSIS

The methodology used in this work is known as OAT (One-at-a-time) method which is a local approach. The term ‘local’ refers to the fact that all the derived cases are taken with respect to a single point, also known as the baseline. The characteristic of the baseline point is that it is a safe starting point where the model properties are well known. Then, specific percentage variations (δ , ε) for the sea states calculated by the ECM are considered.

Table 1. Main characteristics of the NREL 5MW wind turbine [9]

Rating	5 MW
Rotor Orientation, Configuration	Upwind, 3 Blades
Control	Variable Speed, Collective Pitch
Rotor, Hub Diameter [m]	126, 3
Hub Height [m]	90
Cut-In, Rated, Cut-Out Wind Speed [m/s]	3 / 11.4 / 25
Rotor Mass [kg]	110 000
Nacelle Mass [kg]	240 000
Tower Mass [kg]	347 460

The cases considered in this work can be observed in Fig. 2. The baseline (star) is taken directly from the ECL (base case) and the sensitivity to: variation of wave height (triangles), variation of spectral peak period (circles), and the case when the same variation for Hs and Tp is applied (squares) are calculated according to Eqs. (6)-(7). The values H_s^* and T_p^* are the wave height and peak period considered for the derived cases.

$$H_s^* = H_s (1 + \delta\%) \quad (6)$$

$$T_p^* = T_p (1 + \varepsilon\%) \quad (7)$$

With all the combinations of the inputs parameters (U_w , H_s , T_p), several coupled simulations are run in FAST. Then, the standard deviations (STD) are calculated from the resulting simulated dynamic responses.

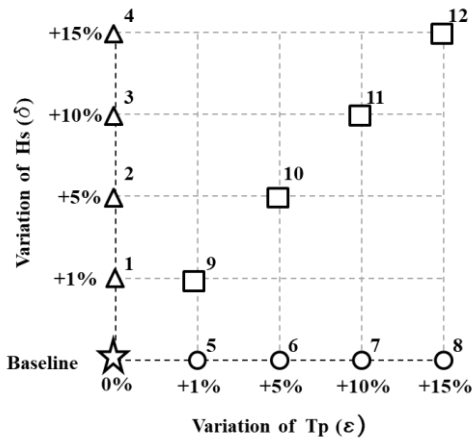

Figure 2. Percentage variation Matrix of the ten sea states selected in each ECL.

Finally, the values are used to find a sensitivity index (S) as indicated by Eq. (8). This indicator helps us to better reflect and quantify the sensitivity (uncertainty propagation) in the short-term response (simulated response) when an uncertainty in the sea state parameters is introduced, which is the main purpose of this work. In a further study, the impact of these uncertainties in a predicted long-term response and, in an ULS analysis can be assessed. However, this analysis is out of the scope of this work and, it will be definitely addressed in a future research.

$$S(Case) = \left(\frac{\sigma_{X_{derived}}}{\sigma_{X_{base}}} - 1 \right) \times 100\% \quad (8)$$

In Eq. (8), $\sigma_{X_{derived}}$ and $\sigma_{X_{base}}$ are the standard deviation of the resulting time serie of the response X , considering the environmental parameters from the baseline case and derived case, respectively. $S(Case)$ represents the sensitivity of the response X to the variations in the environmental parameters for a specific case. All the baseline cases correspond to one of the ten points selected in the ECL. The nomenclature used in the numerical analysis is:

- **S(Hs):** Sensitivity index for the case when the variation is applied only to the wave height (triangles).
- **S(Tp):** Sensitivity index for the case when the variation is applied only to the peak period (circles).
- **S(HsTp):** Sensitivity index for the case when the same variation is applied to the wave height and peak period (squares).

5. NUMERICAL ANALYSIS

The site selected for the analysis is the one presented by Li et al. [11] labelled as “Site 15”. This site is located in the North Sea Center, see Fig. 3. The models considered for representing the environmental stochastic processes are summarized in Table 2. The respective parameters for the probability distributions can be found in the previously mentioned study. As a reference, the 50-year return extreme parameters for this locations are $U_{10}=27.20$ m/s, $H_S=8.66$ m and $T_P=6.93$ s.



Figure 3. Location of “Site 15” [11].

In this analysis, two operational mean wind speeds at hub height are considered, the rated and the cut-out wind speed. In order to use the marginal distribution of the mean wind speed, it is necessary to transform these wind speeds to a height of 10 m above the mean sea level. This task can be done by considering the wind profile power law, Eq. (9).

$$U_{90} = U_{10} \left(\frac{Z_{90}}{Z_{10}} \right)^\alpha \quad (9)$$

The wind shear power exponent (α) is taken as 0.14 according to the IEC-61400 [12]. Therefore, the mean wind speeds to be used in the marginal and conditional distributions for the environmental contour method (ECM) are presented in Table 3. For each operational wind speed, an ECL is generated. Ten sea states are selected in each ECL (Base Case), see Fig. 4 and 5. These points have been selected according to the following criteria: i) trying to have the points equally distributed along the ECL and, ii) choosing important points e.g. point with the highest/lowest Hs, the highest/lowest Tp.

Table 2. Probability models for the joint environmental distributions.

Parameter	Model
Mean wind speed at 10 meters height (u_w)	Marginal - Weibull 2 parameters
Significant wave height (H_s)	Conditional – Weibull 2 parameters
Wave spectral peak period (T_p)	Conditional – Log-normal

Table 3. Mean wind speeds considered in the analysis.

U_w	U_{90}	U_{10}
Rated (m/s)	11.4	8.38
Cut-out (m/s)	25	17.64

The corresponding sea states selected from the ECLs are summarized in Table 4 and, the values of the respective exceedance probabilities (Q) are presented in Table 5, as well as the value of the joint probability.

Table 4. Sea states considered in ECL for rated wind speed (11.4 m/s) and cut-out wind speed (25 m/s).

Sea State	$U_w=11.4$ m/s		$U_w=25$ m/s	
	H_s [m]	T_p [s]	H_s [m]	T_p [s]
1	0.212	0.906	0.821	0.738
2	0.086	6.434	1.453	5.273
3	0.305	14.462	2.432	9.575
4	0.672	20.482	4.167	13.018
5	1.452	23.602	6.571	14.527
6	2.935	20.103	7.908	12.272
7	3.941	15.512	7.065	8.741
8	4.380	10.705	5.606	6.136
9	3.636	5.504	4.093	4.089
10	1.751	2.042	2.630	2.447

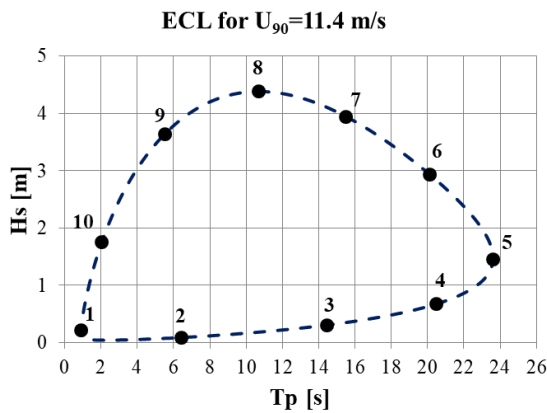

Figure 4. Contour line for a return period $N=50$ years, $U_w=11.4$ m/s (dashed) and, selected sea states (circles).

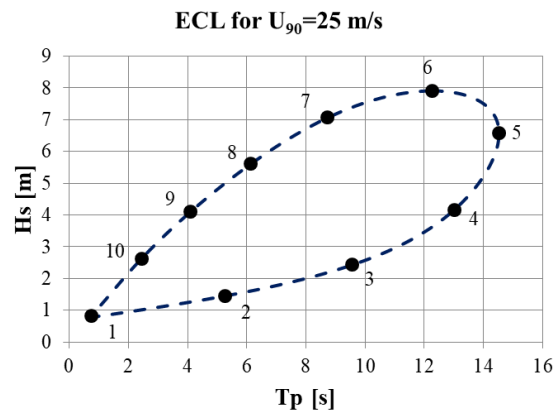

Figure 5. Contour line for a return period $N=50$ years, $U_w=25$ m/s (dashed) and, selected sea states (circles).

Table 5. Exceedance probabilities of environmental conditions in each ECL and their joint probability.

Sea State	$Q_{U_w}(u_{rated})=42.04\%$		Joint Probability	$Q_{U_w}(u_{cut-out})=0.51\%$		Joint Probability
	$Q_{H_s U_w}(h u)$	$Q_{T_p U_w,H_s}(t u,h)$		$Q_{H_s U_w}(h u)$	$Q_{T_p U_w,H_s}(t u,h)$	
1	99.940%	99.940%	5.46E-6	99.992%	70.020%	2.49 E-6
2	99.997%	1.313%	1.50 E-6	99.842%	0.843%	0.29 E-6
3	99.802%	0.019%	0.27 E-6	97.794%	0.064%	0.16 E-6
4	97.352%	0.002%	0.13 E-6	70.147%	0.008%	0.18 E-6
5	71.147%	0.000%	0.11 E-6	2.522%	0.057%	0.35 E-6
6	3.126%	0.001%	0.19 E-6	0.007%	50.000%	0.62 E-6
7	0.011%	0.355%	0.35 E-6	0.479%	99.726%	0.68 E-6
8	0.000%	50.007%	0.59 E-6	19.643%	99.989%	0.60 E-6
9	0.089%	99.960%	0.89 E-6	72.368%	99.991%	0.55 E-6
10	53.198%	100.000%	1.31 E-6	96.721%	99.955%	0.65 E-6

The data presented in Table 4 is taken as baseline input data for the FAST model. The wind field is generated in TurbSim [13] considering the mean wind speed at the hub and, the wind profile power law. Main details of the configurations considered for the simulation of wind and wave conditions are presented in Tables 6-8. Regarding Table 8, the Morison Coefficients (C_d , C_a and, C_p) are very important to determine

with a proper accuracy the dynamic responses. According to [14] the usual parameter ranges for fixed structures are: $1.5 \leq C_p + C_a \leq 2$ and, $0.6 \leq C_d \leq 1.2$. The pressure coefficient (C_p), also known as the Froude-Krilov coefficient, can be usually considered 1 for slender circular cylinder. Therefore, the values taken for this work will be the mean of the range ($C_d=0.9$, $C_a=0.75$, $C_p=1$).

Table 6. General data considered for the simulation of wind conditions.

Parameter	Value
Turbulence Model	Kaimal
IEC turbulence characteristic	B
IEC turbulence type	NTM
Wind profile type	Power Law
Height of the reference wind speed	90 m
Mean (total) wind speed at the reference height [m/s]	11.4 / 25
Power law exponent	0.14
Coherence model	IEC 61400-1 3° ed.
Simulated Time [s]	1200
Time Step [s]	0.05

Table 7. General data considered for the simulation of sea conditions.

Parameter	Value
Incident wave kinematics model	JONSWAP
Peak-shape parameter	3.3
Analysis time for incident wave calculations [s]	3630
heading direction	0°
Water depth [m]	20

Table 8. Data of monopile model.

Parameter	Value
Diameter of the Pile [m]	6
Thickness of the Pile [m]	0.06
Young's Modulus [N/m ²]	2.1E+11
Shear Modulus [N/m ²]	8.08E+10
Density [kg/m ³]	8050
Drag Coefficient (Cd)	0.9
Added Mass Coefficient (Ca)	0.75
Forude-Krilov/Pressure Coefficient (Cp)	1

In Figs. 6-7 the influence of these parameters in the standard deviation of two main structural responses can be observed. These figures show that, the Cd affects much lower the STD of the responses analysed. It varies over a range of $\pm 0.4\%$ for the shear force and $\pm 0.1\%$ for the bending moment (Fig. 6). On the other hand, the parameter Ca has a major effect in the dynamic responses and makes the STD to change over a range of $\pm 15\%$ for the shear force and $\pm 3\%$ for the bending moment (Fig. 7). As it can be found in the literature, the Morison parameters depend on Reynolds number, Keulegan-Carpenter number and the relative roughness but, for this analysis, the mean values could serve as a good start.

6. RESULTS

Prior to process and analyse the results obtained from coupled simulations in FAST, it is necessary to consider the context and nature of the responses in order to identify the most representatives for the purposes of this work.

The first aspect to consider is that, any tridimensional structural system has six degrees of freedom. However, in this study, the corresponding dynamic responses related to the vertical axis (z-axis) are ignored because the monopile model is considered fixed at the seabed (no displacement) and the rotational effect in that axis is considered almost constant for all the cases. The second aspect is related to the side-to-side direction (y-axis). As we are considering a heading angle of 0° for wind and wave, the dynamic responses in y-axis will be mostly a result of the gust component. The value of that perturbation is smaller compared with the full wind field in the fore-aft direction (x-axis). Therefore, analyse the responses associated with that direction will not give useful information in this case. Finally, there are many critical points in the monopile wind turbine that are usually regarded by designers and researchers (blade root, top of tower, transition piece, etc). However, for the purposes of this work, it is necessary to identify the point which better reflects the combined action of wind and wave. The point of interest in this work is where the seabed joints with the monopile, which is also known as mudline (ML).

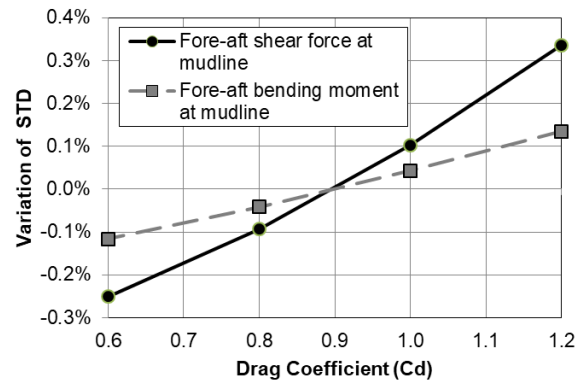

Figure 6. Influence of drag coefficient in the standard deviation of dynamic responses.

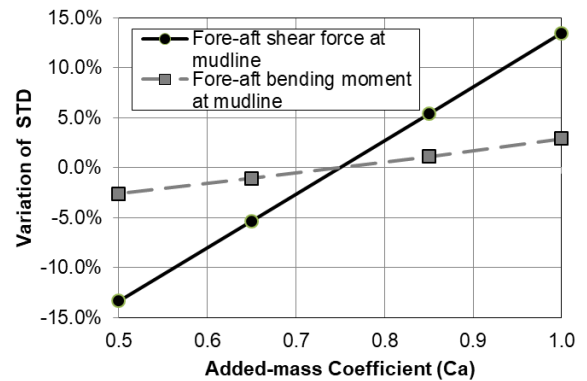

Figure 7. Influence of added-mass coefficient in the standard deviation of dynamic responses.

In summary, attending the reasons exposed above, only the results for the fore-aft shear force (F_x) and fore-aft bending moment (M_y) at mudline are presented in the following sections. Fig.8 shows the time series M_y response for rated wind speed and sea state 8, as example. In all cases, the first 60 seconds of simulation, the transient part, are ignored in order to have more realistic sensitivity indexes.

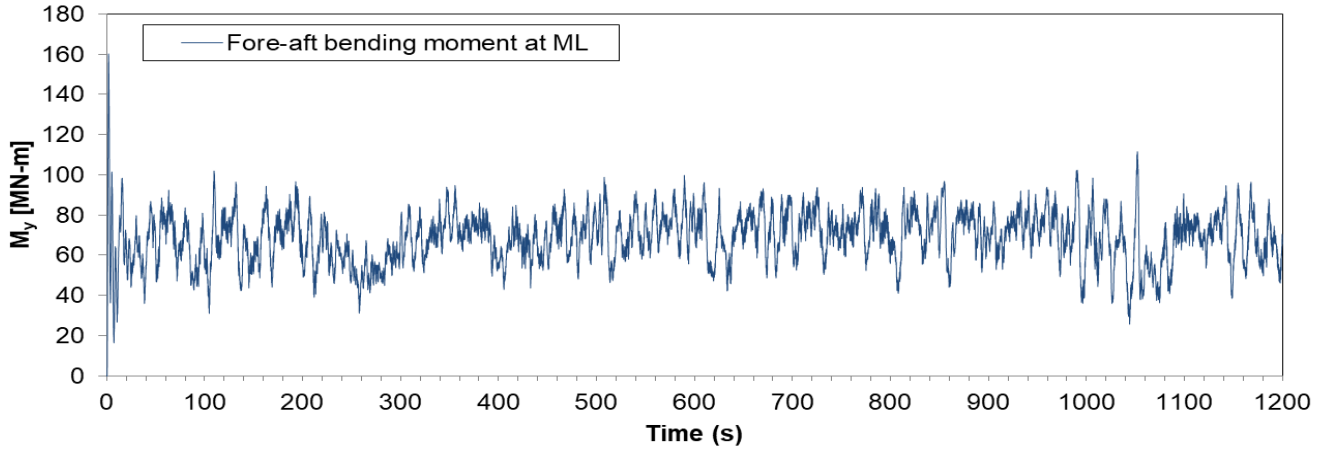

Figure 8. Fore-aft bending moment at mudline for $U_w=11.4$ m/s and Sea State 8 (Mean=68.78 MN-m, Stand. Dev.= 12.72 MN-m)

As a reference, the relation between the maximum hydrodynamic load and the maximum aerodynamic load for the sea states with the largest significant wave height are 1.97 ($U_w=11.4$ m/s, $H_s=4.380$ m, $T_p=10.705$ s) and, 7.04 ($U_w=25$ m/s, $H_s=7.908$ m, $T_p=12.272$ s).

The effect of the change in the sea states parameters can be more evident in a spectrum plot. Figs. 9-10 show the spectrum of F_x for $U_w=25$ m/s and sea state 6 as examples. These spectrums have been calculated with the WAFO tool [15]. Fig. 9 shows the spectrum for the baseline and derived cases where the T_p has not suffer any variation. In this case, an upward displacement in the peak value can be noticed as long as the H_s increases and, the peak frequency remains the same for all the cases. On the other hand, Fig. 10 shows the spectrum for the cases in which the H_s does not suffer any change with respect to its baseline case. As expected, a decrement in the peak frequency can be observed as long as the T_p increases.

Figures 11-14 show some exemplary cases where the relation between the sensitivity indexes and the percentage variations in a specific environmental condition can be observed. It is noticed a very clear linear relationship between $S(H_s)$ and its percentage variation (triangles) whereas the relation between $S(T_p)$ and $S(H_s T_p)$ to their respective percentage variations, could be well represented by a nonlinear function of second degree (circles and squares, respectively). Therefore, the sensitivity indexes can be modelled as Eqs. (10)-(12)

$$S(H_s) = A * (\delta) \quad (10)$$

$$S(T_p) = B_1 * (\varepsilon)^2 + B_2 * (\varepsilon) \quad (11)$$

$$S(H_s T_p) = C_1 * (\delta)^2 + C_2 * (\delta) \quad (12)$$

Where δ and ε are the variations expressed in percentages. $S(H_s)$, $S(T_p)$ and $S(H_s T_p)$ are the sensitivity indexes and, the coefficients A , B_1 , B_2 , C_1 , C_2 can be found with a regression analysis using the least squares method. The goodness of the fitting values can be measured by the coefficient of determination (r^2). Tables 9 and 10 summarize the values of the r^2 coefficients for each environmental condition and each sensitivity index. The coefficients are coloured according to the goodness of fitting, green for the

best relationships and red for the worst cases. Table 9 is referred to the fore-aft shear force at mudline (F_x) whereas Table 10 is for the fore-aft bending moment at mudline (M_y). In both cases, the coefficients are grouped by the mean wind speed considered in the simulation. In general, the r^2 coefficients show that the sensitivity coefficients fit well to the linear and quadratic models. Only few cases have an r^2 lesser than 98% with a minimum of 91.17%.

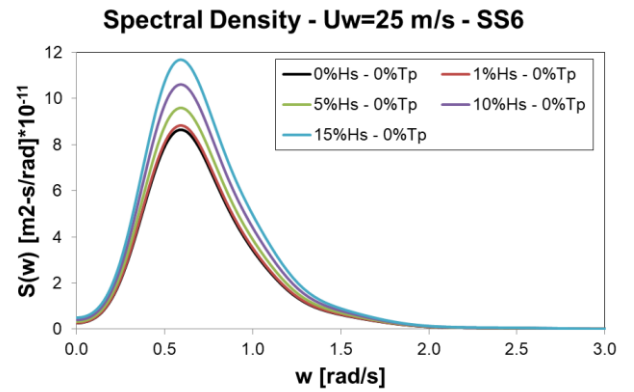

Figure 9. Spectrum of F_x for $U_w=25$ m/s, $H_s=7.91$ m, $T_p=12.27$ s and, $e=0\%$.

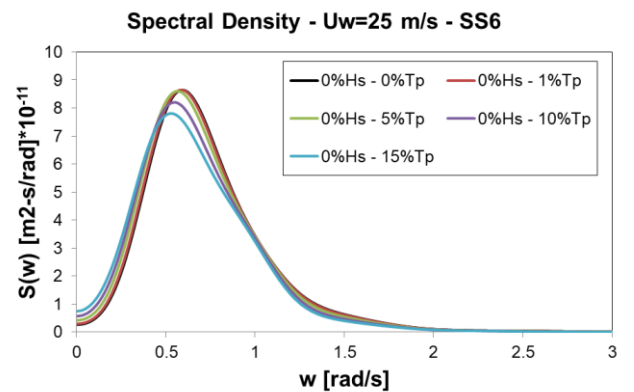

Figure 10. Spectrum of F_x for $U_w=25$ m/s, $H_s=7.91$ m, $T_p=12.27$ s and, $\delta=0\%$.

In order to develop a model which could predict any sensitivity coefficient in the corresponding ECL, it is necessary to use a polynomial regression model which could be able to represent all the sensitivity coefficients as a function of the wave height and peak period for any sea state.

In our case, for a polynomial interpolation, it is necessary to define two vectors which reflect the degree of the polynomial model, Eqs. (13)-(14). The fitting polynomial is represented by a matrix (P) which contains its coefficients, according to Eq. (15), and through a matrix multiplication, Eq. (16) any specific sensitivity coefficient (SCF) can be obtained. Additionally, there is also possible to use the expanded formula for this polynomial, Eq. (17).

$$\vec{H}_S = [1 \quad H_S \quad H_S^2 \quad H_S^3] \quad (13)$$

$$\vec{T}_P = [1 \quad T_P \quad T_P^2 \quad T_P^3] \quad (14)$$

$$P_k = \begin{bmatrix} p_{00} & p_{01} & p_{02} & p_{03} \\ p_{10} & p_{11} & p_{12} & 0 \\ p_{20} & p_{21} & 0 & 0 \\ p_{30} & 0 & 0 & 0 \end{bmatrix}_k \quad (15)$$

$$\{CF\}_k = \vec{H}_S \cdot P_k \cdot \vec{T}_P^T \quad (16)$$

$$\{SCF\}_k = \sum_{i=0}^n \sum_{j=0}^n \{p_{ij}\}_k \cdot H_S^i \cdot T_P^j \quad (17)$$

A third degree has been considered necessary because the relation between the wave height and spectral peak period is a non-injective function and shows a nonlinear behaviour (See Fig. 4 and 5). However, we will see in the next paragraphs that in some cases there could be some terms that can be neglected as their contribution to the sensitivity index calculation is very low. The fitted p-coefficients, Eq. (15), are summarized in Table 11 (Fore-Aft Shear Force - Fx) and 12 (Bending Moment at mudline - My).

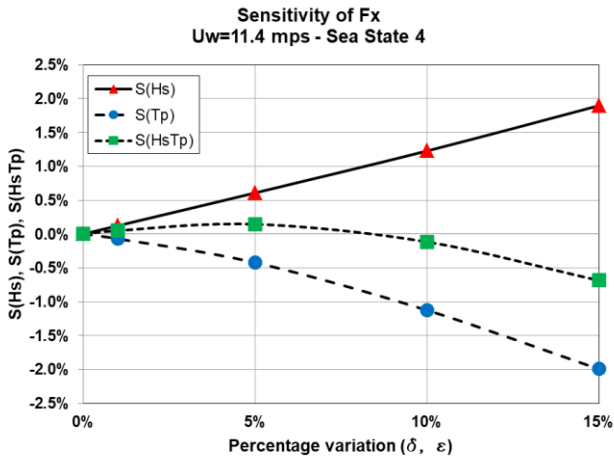

Figure 11. Sensitivity plot of Fx for Uw=11.4 m/s and sea state 4.

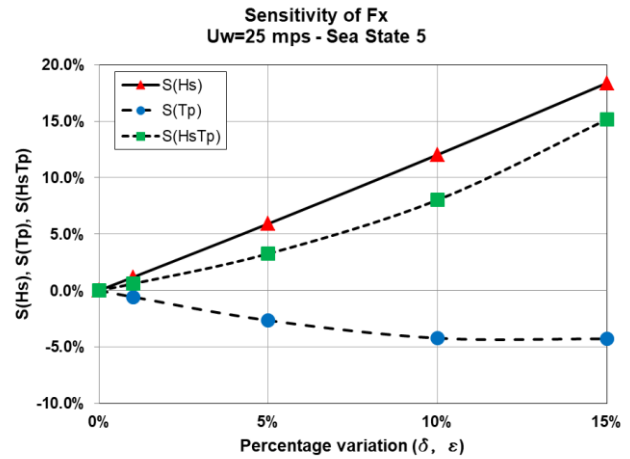

Figure 12. Sensitivity plot of Fx for Uw=25 m/s and sea state 5.

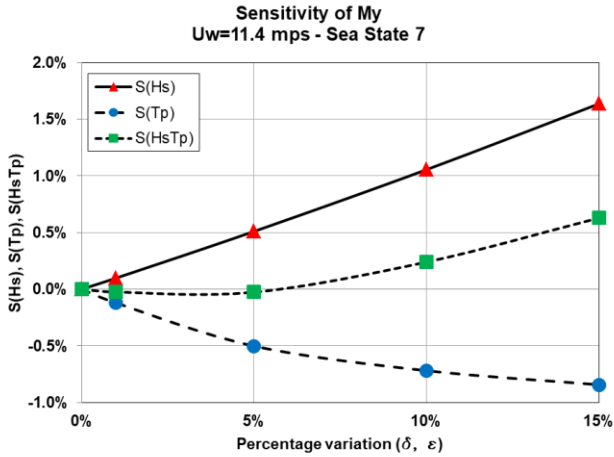

Figure 13. Sensitivity plot of My for Uw=11.4 m/s and sea state 7.

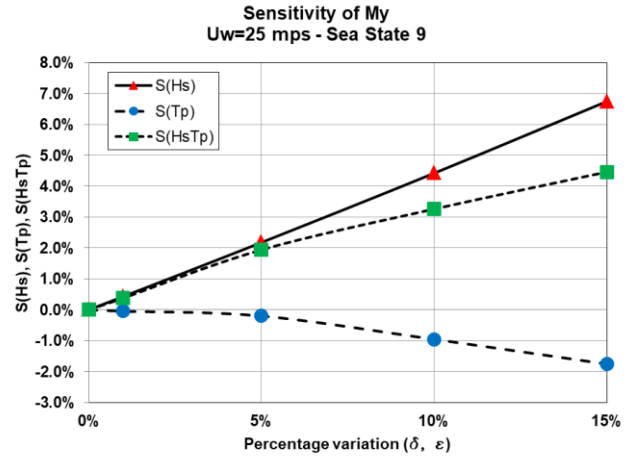

Figure 14. Sensitivity plot of My for Uw=25 m/s and sea state 9.

Table 9. Coefficient of determination of sensitivity indexes for fore-aft shear force at mudline.

EC		1	2	3	4	5	6	7	8	9	10
U _{RATED}	S(Hs)	99.97%	99.88%	99.97%	99.98%	99.98%	99.99%	100.00%	100.00%	100.00%	100.00%
	S(Tp)	100.00%	99.33%	99.75%	99.99%	99.88%	100.00%	99.91%	99.99%	100.00%	99.47%
	S(HsTp)	99.80%	99.76%	96.79%	99.90%	98.16%	99.92%	99.98%	99.98%	100.00%	99.96%
U _{CUT-OUT}	S(Hs)	99.99%	100.00%	100.00%	100.00%	99.99%	99.99%	100.00%	100.00%	100.00%	100.00%
	S(Tp)	100.00%	99.83%	99.87%	99.99%	99.97%	97.13%	96.90%	98.04%	99.96%	99.92%
	S(HsTp)	100.00%	100.00%	96.84%	99.98%	99.98%	99.97%	99.94%	100.00%	100.00%	99.95%

Table 10. Coefficient of determination of sensitivity indexes for fore-aft bending moment at mudline.

EC		1	2	3	4	5	6	7	8	9	10
U _{RATED}	S(Hs)	99.98%	99.65%	99.70%	97.49%	98.67%	99.92%	99.96%	99.98%	99.99%	99.97%
	S(Tp)	99.99%	99.78%	99.02%	99.86%	99.98%	100.00%	99.86%	100.00%	100.00%	99.95%
	S(HsTp)	91.17%	99.85%	99.04%	99.85%	99.97%	100.00%	99.65%	99.75%	100.00%	99.92%
U _{CUT-OUT}	S(Hs)	99.97%	99.98%	99.98%	99.97%	99.94%	99.97%	99.99%	99.99%	99.99%	99.97%
	S(Tp)	99.98%	100.00%	99.96%	99.99%	99.94%	99.85%	99.75%	99.94%	99.67%	99.99%
	S(HsTp)	99.70%	100.00%	99.95%	99.93%	99.88%	99.97%	99.92%	99.99%	99.96%	99.54%

As two operational wind speeds, two dynamic responses, and five sensitivity coefficients have been considered then, there are 20 SCF to predict. Each specific coefficient can be identified by the index 'k' where $k \in \{1,2,3, \dots, 20\}$. In both cases, they are referred to their specific operational wind speed, and are presented with their respective r^2 parameter to show the goodness of the fit. In general, the polynomial models show good fitting, only the SCF C_2 for F_X and M_Y and, C_1 for M_Y have a low r^2 value but, they could be still considered to be acceptable as they are over 88%.

These p-coefficients (P-CF) allow us to compare the sensitivity coefficient models. The first thing that can be observed is that, the absolute values of most of the P-CF for the rated wind speed are relatively lesser than the respective values corresponding to the cut-out wind speed. From Tables 11-12, it is noticed that many P-CF have absolute values near to zero around an order of 10^{-2} or even much lesser. The P-CF in the bottom of the table ($p_{30}, p_{21}, p_{12}, p_{03}$) are more significant because they are coefficients for third degree terms ($Hs^3Tp^0, Hs^2Tp^1, Hs^1Tp^2$, etc.). Therefore, when the multiplication is done, the whole product acquires

importance for determining the corresponding sensitivity index. In contrast, low P-CF in the top of the table ($p_{00}, p_{10}, p_{01}, p_{20}$, etc.) mean that their contribution to the sensitivity index could be neglected specially for the independent (p_{00}) and linear terms (p_{10} and p_{01}).

From the previously exposed paragraph, for cut-out wind speed all the terms are relevant for the sensitivity indexes as all the P-CF are relatively high. On the other hand for the rated wind speed, there are some low degree terms that are very small and they can be probably set to zero in a new regression analysis considering lesser terms, for example, if we see Table 12, $X=M_Y$, $U_w=11.4$ m/s, $k=1$, the coefficient p_{01} is $4.76E-04$ (≈ 0). As a consequence, if the coefficients p_{00} (Hs^0Tp^0 term) and p_{01} (Hs^0Tp^1 term) for F_X and M_Y at rated wind speeds are analysed, it could be observed that in many cases they have very low values. Therefore, in those cases the terms have low contribution to the SCF and it means that a variation in the base case wave height will impact more in the calculation of the sensitivity coefficients than the peak period.

Table 11. Fitted polynomial coefficients for Fore-Aft Shear Force at mudline (F_x).

{P _{ij} }	U _w =11.4 m/s					U _w =25 m/s				
	A {k=1}	B ₁ {k=2}	B ₂ {k=3}	C ₁ {k=4}	C ₂ {k=5}	A {k=6}	B ₁ {k=7}	B ₂ {k=8}	C ₁ {k=9}	C ₂ {k=10}
p ₀₀	-0.136	1.511	1.21E-03	2.152	-0.182	0.572	-4.599	0.896	-3.337	1.508
p ₁₀	0.963	5.287	-1.548	4.592	-0.679	0.898	70.190	-14.720	67.880	-14.880
p ₀₁	3.45E-02	-0.791	5.39E-02	-1.027	0.110	-0.665	-71.580	14.380	-71.140	14.780
p ₂₀	-0.562	8.770	1.85E-02	12.220	-0.770	-0.391	-53.740	10.450	-53.570	10.850
p ₁₁	0.286	-12.820	1.092	-15.900	1.670	0.316	58.800	-10.910	59.690	-11.450
p ₀₂	-7.48E-03	0.230	-1.87E-02	0.290	-3.18E-02	6.28E-02	2.748	-0.725	2.471	-0.708
p ₃₀	3.66E-02	2.44E-02	-0.146	-0.217	-0.104	2.85E-02	1.396	-0.385	1.146	-0.379
p ₂₁	-2.20E-02	1.063	-7.99E-02	1.336	-0.127	-4.38E-02	-2.874	0.693	-2.585	0.694
p ₁₂	-7.88E-03	0.353	-3.24E-02	0.435	-4.83E-02	2.03E-02	0.606	-0.200	0.440	-0.191
p ₀₃	8.93E-05	-2.67E-03	3.02E-04	-3.31E-03	4.58E-04	-1.00E-02	-0.887	0.190	-0.857	0.193
r ²	100.00%	99.71%	99.96%	99.78%	100.00%	99.98%	99.75%	96.08%	100.00%	88.41%

Table 12. Fitted polynomial coefficients for Fore-Aft Bending Moment at mudline (My).

{P _{ij} }	Uw=11.4 m/s					Uw=25 m/s				
	A {k=11}	B ₁ {k=12}	B ₂ {k=13}	C ₁ {k=14}	C ₂ {k=15}	A {k=16}	B ₁ {k=17}	B ₂ {k=18}	C ₁ {k=19}	C ₂ {k=20}
p ₀₀	-1.25E-03	4.47E-02	3.74E-02	0.132	4.04E-02	0.315	-1.897	0.323	-1.755	0.661
p ₁₀	1.76E-02	0.299	-0.126	0.209	-0.130	-1.425	35.800	-6.274	37.350	-8.318
p ₀₁	4.76E-04	-2.46E-02	-9.67E-03	-5.39E-02	-1.01E-02	1.315	-36.980	6.301	-39.150	8.256
p ₂₀	3.71E-02	0.324	0.156	0.757	0.201	1.080	-27.150	4.606	-28.730	6.148
p ₁₁	9.15E-03	-0.528	-8.90E-02	-0.930	-7.60E-02	-1.087	29.500	-4.919	31.500	-6.510
p ₀₂	-2.01E-04	8.14E-03	1.93E-03	1.55E-02	1.79E-03	-5.50E-02	1.612	-0.291	1.658	-0.374
p ₃₀	-5.57E-03	2.12E-03	-2.06E-02	-3.30E-02	-2.77E-02	-4.70E-02	0.792	-0.152	0.759	-0.211
p ₂₁	-1.79E-03	4.91E-02	9.63E-03	8.87E-02	7.41E-03	7.30E-02	-1.573	0.285	-1.576	0.384
p ₁₂	-3.12E-04	1.38E-02	2.15E-03	2.39E-02	1.75E-03	-2.04E-02	0.376	-7.47E-02	0.350	-0.101
p ₀₃	3.20E-06	-4.31E-05	-1.19E-05	-8.91E-05	-1.13E-05	1.79E-02	-0.469	8.11E-02	-0.490	0.107
r ²	100.00%	99.99%	100.00%	99.98%	99.99%	99.93%	97.85%	99.84%	91.01%	90.64%

nonlinearities have considerable influence in the wave kinematics.

7. CONCLUSIONS AND FUTURE WORK

In the present study, a sensitivity analysis has been performed using the environmental contour method. The main purpose of this work is to investigate the impact in the short-term response (variance propagation) when uncertainty is introduced in the environmental parameters. The traditional ECM is used to select few proper and reasonable sea states for offshore wind application with a 50-yr return period. All the simulations were carried out in the FAST program using the Kaimal and JONSWAP models for wind and wave kinematics, respectively.

The results showed that the relation between the sensitivity indexes of the standard deviations of the responses at mudline can be well represented by functions of the uncertainty of the sea states parameters (δ , ε). A linear relationship was observed when only a variation in the wave height is made. For the case when the variation is applied only to the spectral peak period, and when the same variation is applied to the combination of wave height and peak period, a quadratic relationship was perceived. A polynomial fitting was select to represent the trend of all the sensitivity coefficients in order to predict the sensitivity ratios for other sea states not simulated. These polynomials facilitate the comparison between different conditions and responses, and also help to determine the polynomial terms with higher influence.

Further research has to focus on adding complexities to this procedure. The inclusion of survival strategies and operational modes in the determination of the environmental contour line can increase the accuracy of the fitted models. This can be done by using the Modified Environmental Contour Method (MECM). In this work, the same random seeds have been used for all the simulations, increasing the number of random seeds could help to improve the accuracy of the results and represent better the stochastic nature of the environmental parameters. Finally, as this work is relying on simulations, implementing a higher degree nonlinear hydrodynamic model in FAST can help to represent with a better accuracy the hydrodynamic forces over the structure, especially when shallow water is considered and, the

ACKNOWLEDGEMENTS

The first author wants to thanks the *Consejo Nacional de Ciencia y Tecnología* (CONCYTEC) and the *Fondo Nacional de Desarrollo Científico, Tecnológico y de Innovación Tecnológica* (FONDECYT) for their support to this work through the Doctoral Research Program in Energy of the *Universidad Nacional de Ingeniería* (Lima, Peru). This work was in part supported by the UK EPSRC funded "Resilient Integrated-Coupled FOW platform design methodology (ResIn)" project, grant reference number EP/R007519/1.

REFERENCES

- [1] Saltelli, Andrea, Ratto, Marco, Andres, Terry, Campolongo, Francesca, Cariboni, Jessica, Gatelli, Debora, Saisana, Michaela, and Tarantola, Stefano. *Global Sensitivity Analysis. The Primer*. John Wiley & Sons, (2007). DOI 10.1002/9780470725184.
- [2] Smith, Ralph C. *Uncertainty Quantification: Theory, Implementation, and Applications*. SIAM Computational Science & Engineering Series: Philadelphia, PA, USA, (2014).
- [3] Rinker, Jennifer M. "Calculating the sensitivity of wind turbine loads to wind inputs using response surfaces." *Journal of Physics: Conference Series*. Vol. 753. No. 3. IOP Publishing (2016). DOI 10.1088/1742-6596/753/3/032057.
- [4] Karimirad, Madjid, and Bachynski, Erin E. "Sensitivity Analysis of Limited Actuation for Real-time Hybrid Model Testing of 5MW Bottom-fixed Offshore Wind Turbine." *Energy Procedia* (2017). DOI 10.1016/j.egypro.2017.10.331.
- [5] Horn, Jan-Tore, Jørgen R. Krokstad, and Amdahl, Jørgen. "Long-term fatigue damage sensitivity to wave directionality in extra-large monopile foundations." *Proceedings of the Institution of Mechanical Engineers, Part M: Journal of Engineering for the Maritime Environment* (2018). DOI 10.1177/1475090217727136.

- [6] Robertson, Amy, Sethuraman, Latha , and Jonkman, Jason M. "Assessment of Wind Parameter Sensitivity on Extreme and Fatigue Wind Turbine Loads." *2018 Wind Energy Symposium*. 2018. DOI 10.2514/6.2018-1728.
- [7] Haver, Sverre, and Winterstein, Steven R. "Environmental contour lines: A method for estimating long term extremes by a short term analysis." *Transactions of the Society of Naval Architects and Marine Engineers*. 2009.
- [8] Qinyuan, Li, Michailides, Constantine, Gao, Zhen, and Moan, Torgeir. "A comparative study of different methods for predicting the long-term extreme structural responses of the combined wind and wave energy concept semisubmersible wind energy and flap-type wave energy converter." *Proceedings of the Institution of Mechanical Engineers, Part M: Journal of Engineering for the Maritime Environment* (2018). DOI 10.1177/1475090217726886.
- [9] Jonkman, Jason, Butterfield, Sandy, Musial, Walt, and Scott, George . "Definition of a 5-MW reference wind turbine for offshore system development." Technical Report No. 500-38060. National Renewable Energy Lab.(NREL), Golden (United States), 2009. DOI 10.2172/947422.
- [10] Barahona, Braulio, Jonkman, Jason, Damiani, Rick, Robertson, Amy, and Haymana, Greg. "Verification of the new FAST v8 capabilities for the modeling of fixed-bottom offshore wind turbines." *33rd wind energy symposium*. 2015. DOI 10.2514/6.2015-1205.
- [11] Li, Lin, Zhen Gao, and Torgeir Moan. "Joint environmental data at five european offshore sites for design of combined wind and wave energy devices." *32nd International Conference on Ocean, Offshore and Arctic Engineering Volume 8: Ocean Renewable Energy*. American Society of Mechanical Engineers (ASME). 2013. DOI 10.1115/omae2013-10156.
- [12] International Electrotechnical Commission, IEC 61400-3 - Wind turbines - part 3: design requirements for offshore wind turbines. Technical Standard; 2009.
- [13] Jonkman, Bonnie J., and Buhl, Marshall L. Jr. "TurbSim user's guide". Technical Report No. 500-39797. National Renewable Energy Lab.(NREL), Golden (United States), 2006. <https://nwtc.nrel.gov/TurbSim>.
- [14] Karimirad, Madjid. *Aerodynamic and hydrodynamic loads*. Offshore Energy Structures. Springer, Cham, (2014). 187-221. DOI 10.1007/978-3-319-12175-8_9.
- [15] WAFO Group. "WAFO—A Matlab toolbox for analysis of random waves and loads." Lund Institute of Technology. Lund, Sweden (2000). URL <http://www.maths.lth.se/matstat/wafo>.