



**QUEEN'S  
UNIVERSITY  
BELFAST**

## **Pandemonium Trio perform Drone and Drama v2**

Cullen, B. (Performer), Stapleton, P. (Performer), & Ortiz, M. (Performer). (2019). Pandemonium Trio perform Drone and Drama v2. Performance

### **Document Version:**

Publisher's PDF, also known as Version of record

### **Queen's University Belfast - Research Portal:**

[Link to publication record in Queen's University Belfast Research Portal](#)

### **Publisher rights**

Copyright 2019 The Authors.

### **General rights**

Copyright for the publications made accessible via the Queen's University Belfast Research Portal is retained by the author(s) and / or other copyright owners and it is a condition of accessing these publications that users recognise and abide by the legal requirements associated with these rights.

### **Take down policy**

The Research Portal is Queen's institutional repository that provides access to Queen's research output. Every effort has been made to ensure that content in the Research Portal does not infringe any person's rights, or applicable UK laws. If you discover content in the Research Portal that you believe breaches copyright or violates any law, please contact [openaccess@qub.ac.uk](mailto:openaccess@qub.ac.uk).

## Pandemonium Trio perform Drone and Drama v2

BARRY CULLEN, Queen's University Belfast  
bcullen05@qub.ac.uk  
MIGUEL ORTIZ, Queen's University Belfast  
PAUL STAPLETON, Queen's University Belfast

### 1. PROJECT DESCRIPTION

Pandemonium Trio is Barry Cullen, Miguel Ortiz and Paul Stapleton. Our performance research trio has been set up to explore multiple instantiations of custom-made electronic instruments through improvisation. We are particularly interested in exploiting irregularities in the qualities of circuit components (e.g. imprecise tolerances/values), and how this allows for the development of stylistic differences across multiple instrument-performer configurations. We are also interested in how skill, style and performance techniques are developed in different ways on similar devices over extended periods of time, and how our existing musical practices are reconfigured through such collaborative exchanges.

For this musical performance each performer will use an instrument developed by Barry as part of his research. The instrument is called 'Drone & Drama v2', and features circuit bent companion units, devised to be patched together in a modular fashion, using the data from a clock crystal and RAM chip. The instrument lends itself to being played slowly, due to the parameters and controls available. The non-intuitive interface does not encourage a player to learn quickly but invites her to spend time finding connections between controls and sounds. Over time the tone shaping affordances are understood and shared, while simultaneously inviting surprises, discovery, confusion; all are the desired outcomes of play.

These modified circuits have been selected to promote *productive instability* within a restricted set of timbral possibilities. The aesthetic of our performance is informed by noise and free improvised music and is offered as a response to the history of electronic music experimentation [1, 2].

### 2. TECHNICAL NOTES

Version one of the instrument for this project was presented as a demo at NIME 2018 as Tri-Sine & Noise Siren. It used the same building blocks of function generators (drone section), circuit bent siren (drama section), mixer and filter. The latest version (Drone and Drama v2) retains most of the form and functionality of the initial design, with changes in interface, connectivity and circuit fabrication.

The instrument consists of several circuits. The function generators [3] and noise siren (which consists of a phase locked loop [4] and timer [5]) create sounds which are then modified (mixed and filtered) before the output can be sent to an amplifier. The combination of these circuits was the result of the

creative studio practice of tinkering with tools and materials: making and modifying. The schematics of the circuits used in the current iteration are below:

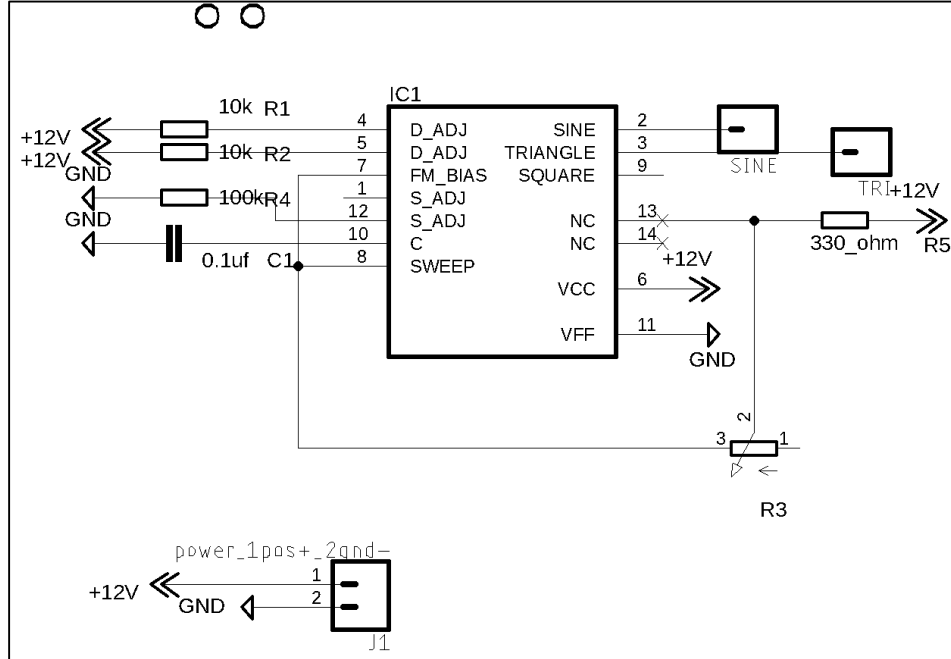

Fig. 1. Sine / Triangle Function Generator.

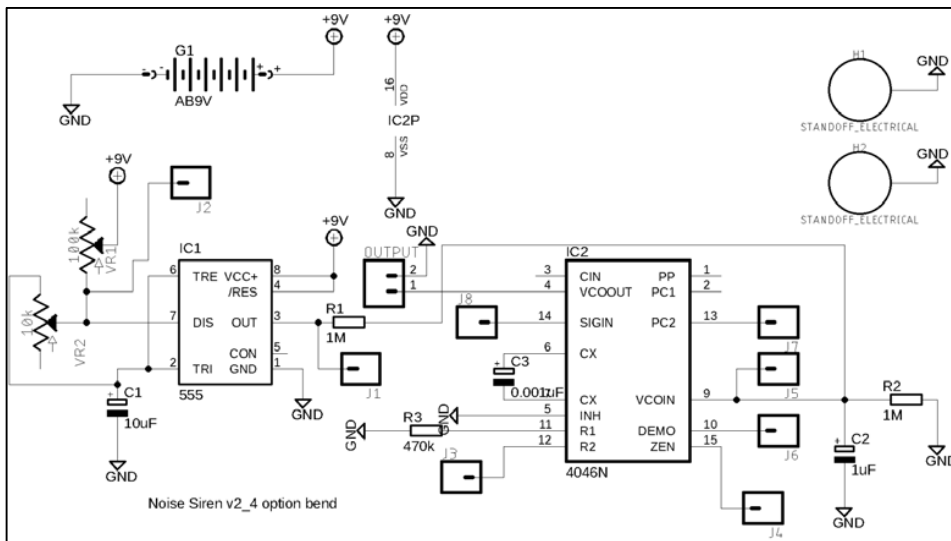

Fig. 2. Circuit bent "Dub siren" (a.k.a. Noise Siren).

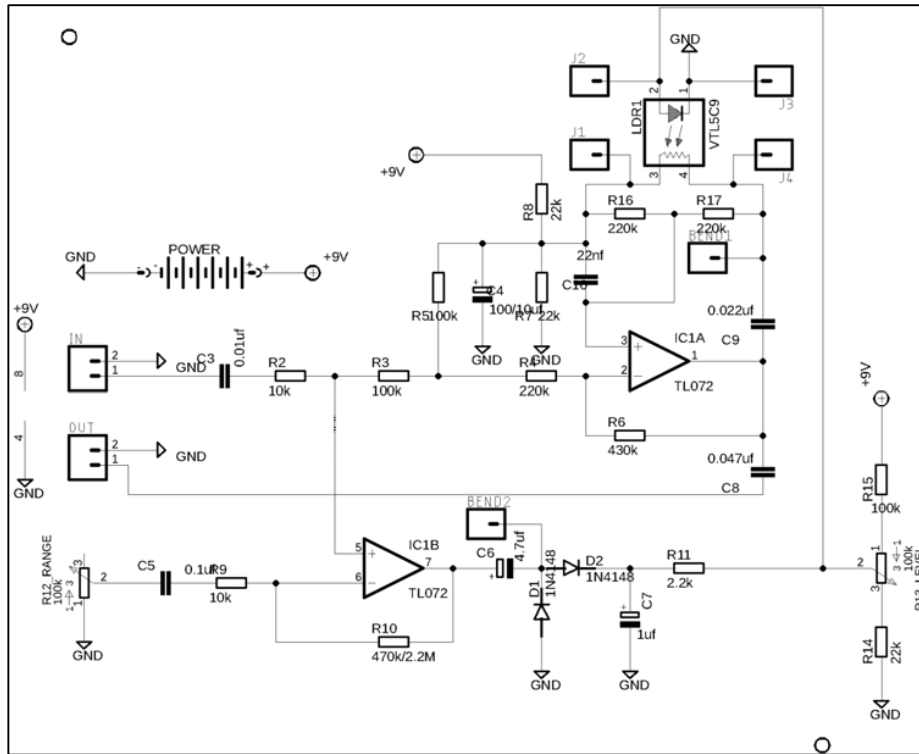

Fig. 3. Circuit bent “440” D.O.D Envelope Filter

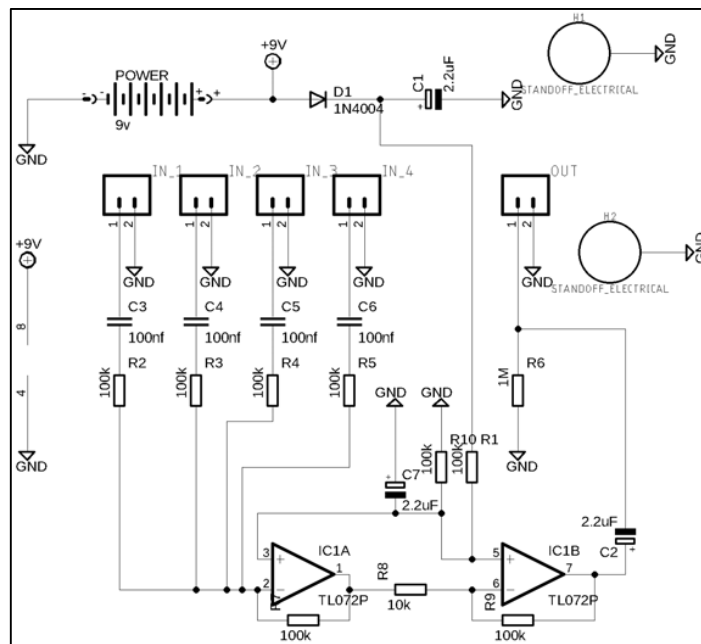

Fig. 4. Four-channel mixer.

The sounds produced by Drone and Drama V2 can also be influenced by external inputs. To expand the range of tones they are fed data from circuit-bent

multi-effects units. The instruments have banana sockets to allow the connections between them to be stacked, which can lead to more complex interaction between the circuits.

The first version of the instrument used touch points instead of banana socket connections. Frequency range toggle switches were removed from the oscillators, and the filter and siren sections were also revised. The latest instrument now uses PCBs instead of vero board for each circuit.

### 3. PROGRAM NOTES

**Pandemonium Trio** is a new group based at the Sonic Arts Research Centre (SARC), dedicated to bring audiences the finest in folktronic audio and cybernetic signals, vibrating together in heart-warming 12V ballads, oscillating between the sacred and the profane.

**Barry Joseph Cullen** is an audio and video worker who has exhibited, performed in Europe, the Middle East, North and South America. His practice includes; DIY electronics, audio technology and motion graphics, interactive AV installation work, foley, print, sound tracks, DJing, VJing, circuit bending, creative technical support and amplified junk. He has recently began research at Sonic Arts research Centre at Queen's University Belfast.  
barryjosephcullen.wordpress.com

**Miguel Ortiz** is a Mexican composer, sound artist, and Lecturer at Queen's University Belfast. His work focuses on the use of sensing technologies for creative applications, specifically Digital Instrument Design and its intersection with Composition and Improvisation. miguel-ortiz.com

**Paul Stapleton** is an improviser, sound artist and instrument inventor originally from Southern California. He performs with a variety of metallic sound sculptures, custom made electronics, found objects and electric guitars in a diverse range of projects. Paul is currently based at SARC in Belfast, where he teaches and supervises research in improvisation, performance technologies and site-specific art. paulstapleton.net

### 4. MEDIA LINK

- Video 1: <https://vimeo.com/313209363>

### ACKNOWLEDGMENTS

This work is supported by the Department for the Economy in Northern Ireland (DfE), the School of Arts, English and Languages (AEL) and the Jack Kerr Fund in Music at Queen's University Belfast.

### REFERENCES

- [1] R. Hordijk, *The Blippoo Box: A Chaotic Electronic Music Instrument, Bent by Design* Leonardo Music Journal Volume 19 - December 2009 p.35-4
- [2] N. Collins, *Handmade Electronic Music: The Art of Hardware Hacking*, Routledge; 2 edition (April 15, 2009)
- [3] Harris Semiconductor, <https://www.mit.edu/~6.331/icl8038data.pdf>
- [4] Texas Instruments, <https://www.ti.com/lit/ds/symlink/cd4046b.pdf>
- [5] Texas Instruments, <https://www.ti.com/lit/ds/symlink/lm555.pdf>