



**QUEEN'S
UNIVERSITY
BELFAST**

Postbuckling of Marine Stiffened Composite Plates with Initial Geometric Imperfections Using Progressive Failure Analysis

Morshedsolouk, F., & Karimirad, M. (2021). Postbuckling of Marine Stiffened Composite Plates with Initial Geometric Imperfections Using Progressive Failure Analysis. *Journal of Marine Science and Application*. Advance online publication. <https://doi.org/10.1007/s11804-021-00232-z>

Published in:

Journal of Marine Science and Application

Document Version:

Peer reviewed version

Queen's University Belfast - Research Portal:

[Link to publication record in Queen's University Belfast Research Portal](#)

Publisher rights

Copyright 2021 Harbin Engineering University and Springer-Verlag GmbH Germany, part of Springer Nature 2021. This work is made available online in accordance with the publisher's policies. Please refer to any applicable terms of use of the publisher.

General rights

Copyright for the publications made accessible via the Queen's University Belfast Research Portal is retained by the author(s) and / or other copyright owners and it is a condition of accessing these publications that users recognise and abide by the legal requirements associated with these rights.

Take down policy

The Research Portal is Queen's institutional repository that provides access to Queen's research output. Every effort has been made to ensure that content in the Research Portal does not infringe any person's rights, or applicable UK laws. If you discover content in the Research Portal that you believe breaches copyright or violates any law, please contact openaccess@qub.ac.uk.

Open Access

This research has been made openly available by Queen's academics and its Open Research team. We would love to hear how access to this research benefits you. – Share your feedback with us: <http://go.qub.ac.uk/oa-feedback>

Postbuckling of Marine Stiffened Composite Plates with Initial Geometric Imperfections Using Progressive Failure Analysis

Fattaneh Morshedsolouk^{1*} and Madjid Karimirad²

1. Faculty of Mechanical Engineering, Babol Noshirvani University of Technology, Babol 47148 – 71167, Iran

2. School of Natural and Built Environment, Queen's University Belfast (QUB), Belfast BT9 5AG, United Kingdom

Abstract: This work explores the postbuckling behavior of a marine stiffened composite plate in the presence of initial imperfections. The imperfection shapes are derived from buckling mode shapes and their combinations. Thereafter, these imperfection shapes are applied to the model, and nonlinear large deflection finite element and progressive failure analyses are performed in ANSYS 18.2 software. The Hashin failure criterion is employed to model the progressive failure in the stiffened composite plate. The effect of the initial geometric imperfection on the stiffened composite plate is investigated by considering various imperfection patterns and magnitudes. Results show that when the magnitude of the imperfection is 20 mm, the ultimate strength of the stiffened composite plate decreases by 31%. Moreover, global imperfection shapes are found to be fundamental in determining the ultimate strength of stiffened composite plates and their postbuckling.

Article Highlights

- The effect of initial geometric imperfection mode shapes and magnitude on the ultimate strength of the stiffened composite panels are studied.
- The 11th first buckling mode shapes and a series of combinations of them are assumed as initial geometric imperfections.
- The postbuckling and damage are modeled using the progressive damage method and nonlinear finite element method.

Keywords: Initial Geometric Imperfection, Laminated Composite Plate, Postbuckling Behavior, Nonlinear Finite Element method, Progressive damage method, Hashin damage criteria

Article ID: 1671-9433(2018)02-0000-00

1 Introduction

Using stiffened laminated composite plates in marine structures can decrease their weight, increase their production speed, and decrease their life cycle cost. Thus, the application of laminated composite materials in offshore and ship structure fields has broadened rapidly. Many marine structures are made of composite materials. In ships, composite materials are used to manufacture hull structures, decks, bulkheads, and topsides. In general, these structures consist of

plates that are stiffened in two orthogonal directions. During a ship's lifetime, its stiffened plates are exposed to various loads, with hull girder stress being the dominant one. Such type of load is due to the bending of the whole ship hull, similar to a simple beam.

As a result of the precise and advanced construction methods utilized in the last decade, relatively thin and light stiffened composite plates have been adopted in ship structures. Therefore, these structures have become increasingly prone to the buckling behavior of ship decks or floor structures under in-plane hull girder stress. Zhu et al., 2015 experimentally studied the effect of stiffeners' stiffness and plate thickness on the ultimate strength of marine composite stiffened panels and concluded that plate thickness exerts a considerable effect on the ultimate strength of composite stiffened panels. To comprehend the postbuckling behavior of composite stiffened panels, Bai et al., 2018 investigated the strength of a composite stiffened panel by conducting some experiments.

Barsotti et al., 2020 indicated that the macro-mechanical aspects of mechanical properties are widely used in the design of composite structures because of their simplicity. Progressive damage methodologies are based on macro-mechanical properties and are commonly utilized to investigate the strength of laminated composite plates and stiffened plates. In their review, Murugestan and Rajamohan, 2017 stated that because of the failure behavior of layered composite structures, progressive failure methods are highly appropriate. On the basis of a progressive failure method for analyzing laminated composites, Chen and Guedes Soares, 2007 developed a technique for investigating the ultimate strength of stiffened composite panels and derived a nonlinear formulation for laminated shell finite elements. Huang et al., 2015 generated a 3D finite element curved beam model to analyze grid stiffened curved panels by using a progressive failure method. The degree of freedom in this beam model is compatible with that of shell elements; hence, the number of unknowns decreases.

Pal and Bhattacharyya, 2007, Pal and Ray, 2002 and Namdar and Darendeliler, 2017 used progressive failure analysis to evaluate the strength of laminated composite plates under transverse loading and shear loading. Priyadharshani et al., 2017 investigated the ultimate strength of various

Received date: 28 April 2020

Accepted date: 30 August 2020

Funding information: No funding

*Corresponding author Email: f.morshed@nit.ac.ir

composite stiffened panels with cutouts by using a finite element method (FEM) and performing experiments. Kong et al., 1998 conducted a series of compression tests on a stiffened composite plate, performed nonlinear finite element analysis, and implemented progressive failure methods to model the compression test results.

The uncertainties correlated with laminated composite structures exert a significant impact on their postbuckling strength. These uncertainties could be presented in material properties, ply thickness, fiber orientation, geometric imperfection, etc. No systematic guideline or standard is available to describe how to consider these uncertainties, especially in the field of marine composite structures. Thus, the effects of various uncertainties on the ultimate strength of stiffened laminated composite plates need to be studied. Considering these uncertainties, Chen and Guedes Soares, 2007; 2008, respectively presented a reliability finite element method and a stochastic finite element method to assess the reliability of composite stiffened panels under compressive loads.

The initial defects during the manufacturing process are one of the main sources of uncertainties in estimating the strength of marine composite structures. Initial defects come in the form of initial delamination, impacted areas, and initial geometrical imperfections. Initial geometric imperfections could decrease the strength of composite stiffened plates. They refer to differences between the configurations of manufactured structures and the ideal design structures. These imperfections are due to the manufacturing process and are impossible to predict. Thus, different methods have been applied to model their effects on the strength of structures.

The postbuckling behavior of stiffened plates and that of unstiffened plates differ significantly. In stiffened plates, the plate panels are surrounded by stiffeners. Hence, their boundary conditions are neither rotationally fixed nor free. Moreover, the stiffeners usually are designed to buckle after the plates; following plate buckling, the load then transfers to the stiffeners. The ultimate strength of stiffened plates is considerably greater than that of unstiffened plates. A large and growing body of literature has focused on the effects of imperfections on the strength of unstiffened rectangular/square laminated plates. These studies have used analytical methods to solve the governing nonlinear equations for the postbuckling of laminated plates.

Stamatelos et al., 2011 and Bisagni and Vescovini, 2009 proposed analytical methods to investigate the buckling and postbuckling strength of stiffened isotropic and orthotropic plates. The former research group modeled stiffeners by using transverse and rotational springs with variable stiffness, while the latter modeled stiffeners by using De Saint Venant torsion bars. They both extended a model to analyze the postbuckling of perfect stiffened panels in local buckling mode with no damage. Ghannadpour and Barekati, 2016 solved the laminated plate equation by using equivalent finite double Chebyshev polynomials. Karrech et al., 2017 presented a method on the basis of energy conjugacy to analyze thick

plates' postbuckling behavior with large geometric imperfections. As they used the Fourier series to solve the governing equations, their method covers a wide range of imperfection shapes.

In analyzing the effects of geometric imperfections on the postbuckling behavior of unstiffened composite plates, many researchers have defined geometric imperfections by using sine or cosine functions. In many analytical solutions, a plate deformation domain is also defined using these functions, and this coordination can facilitate the analysis process. Moreover, many semi-analytical methods for studying the postbuckling of unstiffened rectangular/square laminated panels are available in the literature. In existing studies, the nonlinear large deflection plate equations are solved for various loading and boundary conditions.

To solve the governing equations of imperfect composite plates, Ghannadpour and Shakeri, 2018; 2020 presented a new energy-based collocation method. They discretized the plate region with Legendre–Gauss–Lobatto nodes and used Legendre basis functions for displacements. In this method, the progressive failure of composite plates is also modeled. They proposed three methods to model material degradation. Ghannadpour and Abdollahzadeh, 2020 developed a semi-analytical method to solve the governing nonlinear equations for thick laminated plates under in-plane compression. They applied the Hashin–Rotem failure criteria alongside two degradation methods and first- and higher-order shear deformation theories.

Semi-analytical methods are more versatile than analytical methods as the initial geometric imperfection shapes could be increasingly complicated. In using semi-analysis methods to solve nonlinear composite plate equations, the effects of progressive failure can also be considered. Another method to analyze the imperfect plate strength is the finite stripe method, in which a plate is discretized into stripes. Mittelstedt and Schröder, 2010 and Mittelstedt et al., 2011 solved Marguerre-type equations for imperfect composite plates under longitudinal compression and in-plane shear by using the Galerkin method. They derived a simple closed-form solution for the postbuckling of longitudinally compressed imperfect composite plates. Assaee et al., 2012 presented a semi-energy finite strip formula to analyze the nonlinear postbuckling of an imperfect laminated composite plate with a longitudinal sinusoidal imperfection shape.

Over the last decade, the buckling and postbuckling of unstiffened panels have attracted considerable attention. However, to the best of the authors' knowledge, the studies on the effects of initial geometric imperfections on the postbuckling behavior of stiffened composite plates are scarce. Elseifi et al., 1999 proposed a convex model to evaluate the effects of imperfections on the strength of stiffened plates. They used a linear combination of buckling mode shapes to find the worst-case scenarios for geometric imperfection shapes. This method stipulates that the first derivative of a stiffened plate's ultimate strength concerning each buckling mode amplitude is constant. This assumption is only valid if

the initial geometric imperfections are small. In plates with large geometric imperfections, membrane stress develops along with bending stress. Hence, the form of deformation and the buckling and postbuckling behaviors of these plates are different from those of plates with small initial deformations.

Ambur et al., 2004 used the measured imperfection of a manufactured composite stiffened plate in a finite element model and calculated the postbuckling of the stiffened composite plate. Although this method is very accurate, it is almost impossible to use in estimating the strength of imperfect stiffened plates. Specifically, this method requires one or more full-scale samples of stiffened plates. The plates' geometric imperfections are then measured, and the measurements are used in a finite element model to calculate the strength. More importantly, this method only considers one case of many possible initial geometric imperfection shapes.

Anyfantis and Tsouvalisand, 2012 assumed that a geometric imperfection carried the form of the first buckling mode shape and investigated the postbuckling behavior of stiffened composite plates. They assumed that the magnitude of the imperfection is 1% of the thickness. Morshedsolouk and Khedmati, 2014 and Smith and Dow, 1985 (Smith & Dow, 1985) used the $w^0 = \sum_1^n W_{mn} \sin \frac{\pi x}{a}$ function to model the imperfections of stiffened composite plates. Anyfantis, 2019 studied the effects of local and global geometric imperfections on a stiffened panel's buckling load. The one-factor-at-a-time method (OFTM) and 2^k factorial design method were employed to analyze the results. The significant modes or mode combinations for the buckling of conventional steel marine stiffened panels were specified. The author concluded that in analyzing the postbuckling strength of steel marine stiffened panels, global imperfections and stiffener imperfections are of little importance. Gaitanelis et al., 2019 proposed a method to analyze the in-plane compressive strength of an impacted composite stiffened panel. They used a user-defined progressive damage code in Abaqus in parallel with cohesive zone elements. In their study, they assumed the first eigenvalue buckling mode as the initial geometric imperfection.

Given the lack of research in this field, the present study investigates the effects of initial geometric imperfections on the postbuckling behavior and ultimate strength of marine stiffened composite plates. Given the absence of an approved systematic way to analyze the effects of imperfections on the postbuckling of stiffened composite plates, the best practice is to use the experience and methods in the field of steel structures. Thus, this work adopts the suggestion of EN 1993-1-5, which was also used by Tran et al., 2014. The geometrical nonlinear finite element method is combined with progressive failure analysis and used to study the effects of initial geometric imperfections on the postbuckling behavior, ultimate strength, and load-carrying capacity of a marine composite stiffened plate. This study provides insights into the problem of imperfect stiffened composite plates. Moreover,

the magnitude of imperfection is noted as the maximum initial deformation of the stiffened plate in the y-direction.

2 Finite Element Modeling

Recent advances in nonlinear finite element methods enable us to study the consequences of geometric imperfections in structures at a relatively low cost. As the thickness of stiffened composite plates used in shipbuilding is relatively small, these materials can be modeled using shell elements. Large deflections and composite material fractures due to buckling and progressive failure are considered.

In this study, a composite stiffened plate with practical dimensions applicable to seagoing composite ships is chosen from the study of Chen et al., 2008. The stiffened panel measures 1000 mm long and 456 mm wide, and the span of its stiffeners is 300 mm (Figure 1). The panel is stiffened with two hat-type stiffeners, the cross-section dimensions of which are shown in Figure 2. The problem is solved using the displacement-controlled method. The displacement in the x- and y-directions of line CD is assumed to be zero, and the displacement in the z-direction of line CD is increased incrementally. The nodes on line AB are fixed. Moreover, the rotation on lines AB and CD is constrained. These boundary conditions are expected to produce longitudinal in-plane compression in the z-direction.

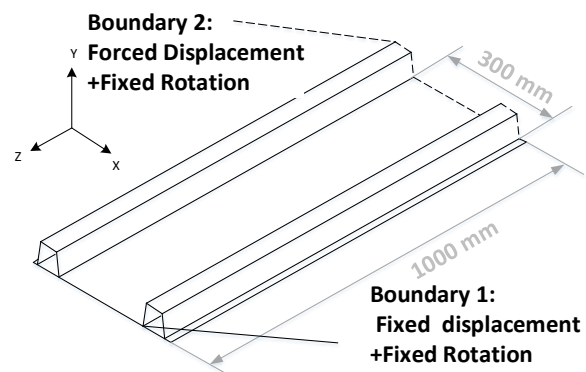

Figure 1: Geometrical dimensions and boundary conditions of the model

The plate and its stiffeners are made of E-glass epoxy woven material that is commonly used in marine applications. Their material properties are presented in Table 1. The stacking sequences of the plate panels and stiffeners are $[0_4/45/0_4/45]_S$ and $[0_5/45/0_5/45]_S$, respectively, given the z-axis in Figure 1.

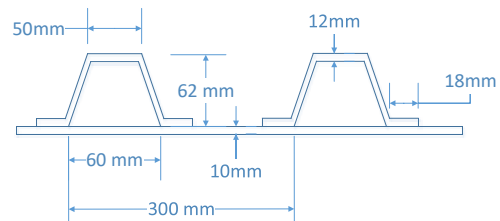

Figure 2: Cross-section dimensions

Table 1: Mechanical properties of the material used in this study

Mechanical Properties	Symbols	Magnitude
Module of Elasticity in the main direction of the material	E_1	15.8 [GPa]
Module of Elasticity in a direction normal to the main direction of the material	E_2	15.8 [GPa]
Shear Modulus in direction 12 and 13	G_{12} and G_{13}	3.5 [GPa]
Shear Modulus in direction 23	G_{23}	0.35 [GPa]
Poisson's Ratio in direction 12 and 13	ν_{12} and ν_{13}	0.13
Tensile strength in direction 1	X_T	249 [MPa]
Compression strength in direction 1	X_C	213 [MPa]
Tensile strength in direction 2	Y_T	249 [MPa]
Compression strength in direction 2	Y_C	213 [MPa]
Shear strength	S	23.5 [MPa]

direction 1 is the laminate's main direction, and direction 2 is the direction normal to direction 1

To simulate the postbuckling of the composite stiffened panels, this study uses progressive failure analysis and geometrical nonlinear properties. Murugesan and Rajamohan, 2017 divided the progressive failure analysis method into three steps: analysis of laminate for stress distribution, application of an appropriate failure criterion, and application

of material or stiffness degradation methods. To implement these steps, the present study conducts postbuckling analysis by using Workbench ANSYS 18.1. The modeling and analysis steps are illustrated in Figure 3 and comprise the following phases:

1) Modeling the composite stiffened plate in the ACP (pre) component system (ACP or Ansys Composite PrepPost is an add-on module for ANSYS for modeling layered composite structures);

2) Defining the boundary conditions in the static structural analysis system, with the buckling modes derived on the basis of the loading conditions defined in this step;

3) Deriving the first 11 buckling modes in the eigenvalue buckling analysis system;

4) Applying the initial geometric imperfection in the mechanical APDL component system (using UPGEOM command and saving the FEM model); in this study, the initial geometric imperfection defined herein on the basis of the maximum initial deformation in the stiffened plate;

5) Preparing the FEM model in the finite element modeler component system;

6) Redefining material properties in the ACP (pre) component system; note that the ACP model cannot be transferred into the mechanical APDL entirely and that only the geometry can be transferred and changed; the properties should be defined again to generate the composite material model;

7) Conducting nonlinear progressive failure analysis of the composite stiffened plate in the static structural analysis system; progressive failure analysis is performed using Hashin's failure criteria (Hashin, 1980).

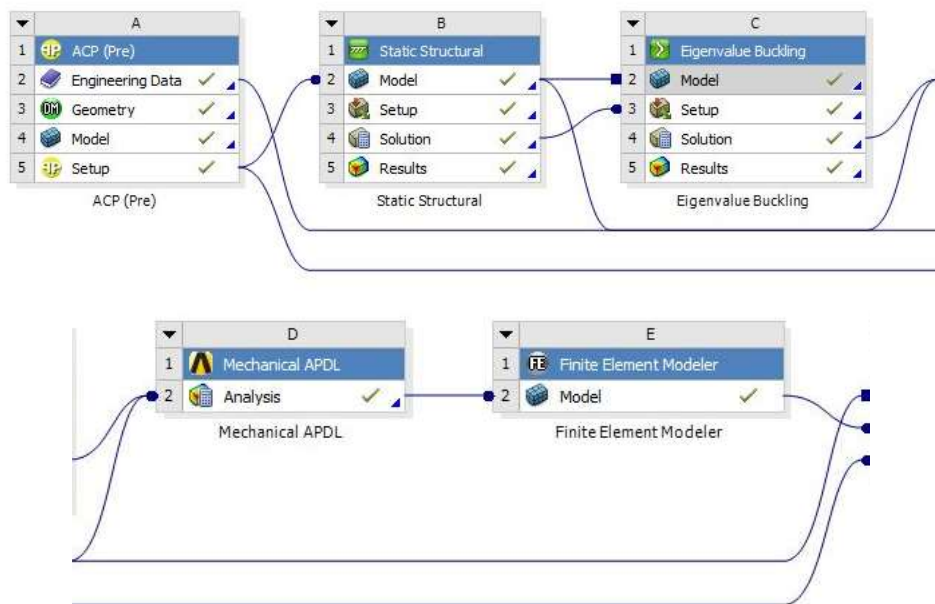

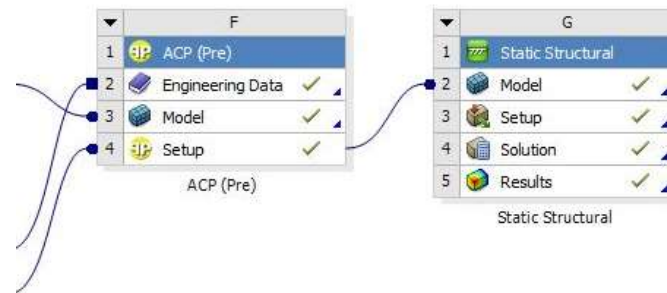

Figure 3: Project schematic in Workbench ANSYS 18.1

2.1 Buckling Mode Shape as Initial Geometric Imperfection

Initial geometric imperfections in composite structures have irregular stochastic local or global shapes. However, they are commonly modeled using buckling mode shapes. (Anyfantis and Tsouvalis, 2012; ANYfantis, 2019; Gaitanelis, et al., 2019; Tran, et al., 2014). In this study, a sensitivity analysis is performed to study the effects of geometric imperfections on the postbuckling of the composite stiffened plates. The imperfection shapes are based on EN 1993-1-5, as described by Tran et al., 2014 and Anyfantis, 2019. They have used four different imperfection shapes in their study, i.e., global buckling mode, local plate panel buckling mode, stiffener torsional buckling mode, and a set of combinations of these modes.

2.2 One-Factor-at-a-Time Method (OFTM)

The first step in understanding the effects of imperfections on stiffened plate strength is the implement the OFTM. In this method, the effect of each imperfection mode is analyzed one by one. Herein, the 1st to 11th buckling mode shapes are considered as initial geometric imperfections, and they are known as the 1st to 11th imperfection modes (Figure 4). The four first modes can be concluded as the local plate buckling mode, while the other modes are combinations of global and local modes.

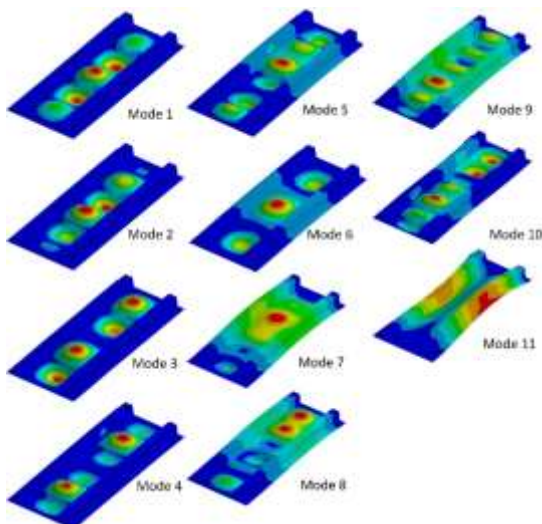

Figure 4: 1st to 11th imperfection modes

2.3 Method of Combined Modes

After analyzing the panels' postbuckling ultimate strength with consideration of all imperfection shapes in the previous section, the maximum in-plane compressive load is illustrated vs. maximum geometric imperfection (modes 1 to 11). Then, the three worst cases are chosen (modes 11, 9, and 7). These initial geometric imperfection modes exert the most effect on the ultimate strength of the stiffened composite plates. In addition to all the considered buckling mode shapes, the effects of a set of linear combinations of these three worst cases as initial geometric imperfections on the stiffened plate's ultimate strength are studied. These combination sets are

- Combination Model A1: $1.0 \times (\text{no. } 11) + 0.7 \times (\text{no. } 9) + 0.7 \times (\text{no. } 7)$
- Combination Model A2: $0.7 \times (\text{no. } 11) + 1.0 \times (\text{no. } 9) + 0.7 \times (\text{no. } 7)$
- Combination Model A3: $0.7 \times (\text{no. } 11) + 0.7 \times (\text{no. } 9) + 1.0 \times (\text{no. } 7)$

Here, no. i is the i^{th} normalized mode shape.

3 Verification of the Numerical Modeling

To validate the proposed method, this work compares the corresponding results with those of Kong et al., 1998. A test was performed to model and analyze the strength of the composite stiffened plate with T-stiffeners. The details of the model and the loading and boundary conditions are given in Kong, 1998. The compressive load-end shortening diagram of this stiffened composite panel is shown in Figure 5. Under the in-plane compressive load, the plate panel first buckles. Meanwhile, with increasing compressive load, the force on the stiffeners increases. In the next level, the stiffeners show flanging, followed by torsional buckling.

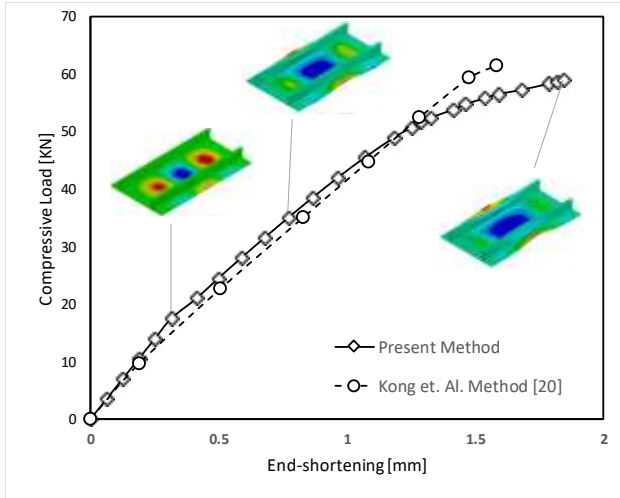

Figure 5: Compressive load-end shortening for composite T-stiffened plate

4 Results and Discussion

In the present study, a series of nonlinear finite element models with progressive failure are explored to investigate the effects of imperfection modes and magnitude on the ultimate strength of a stiffened composite plate. The boundary and loading conditions are illustrated in Figure 1. The ultimate compressive strength of the imperfect stiffened composite plate versus the magnitude of the imperfection for all considered imperfection modes is plotted in Figure 4. In the perfect plate, the ultimate compressive strength is 1.08 MN (average stress of 216 MPa). The plate strength decreases with increasing initial imperfection. The rate of this reduction in ultimate strength depends on the initial imperfection modes. In this regard, the initial imperfections can be divided into three categories:

1. Local imperfections, in which only the plate panels are deformed, i.e., modes 1 to 4 (the results are shown as dashed lines in Figure 6);
2. Global imperfections, in which the stiffeners deform globally, i.e., modes 5 to 11 (the results are shown as bold lines in Figure 6);
3. Combination of three worst cases, i.e., A1, A2, and A3 (dotted lines in Figure 6)
4. In this figure, the results of Case A1 and A2 are very similar; therefore, the results are shown as one line.

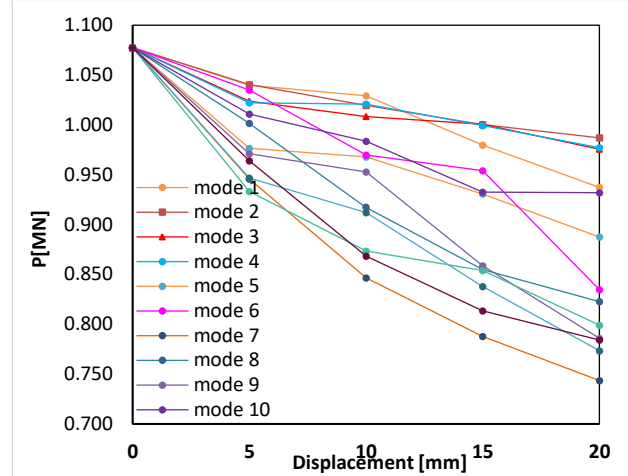

Figure 6: Maximum in-plane compressive load – maximum geometric imperfection

When the magnitude of the imperfection is 20 mm and the imperfection is in the local mode, the ultimate compressive strength of the stiffened composite plate shows a 13% drop. Meanwhile, even a small imperfection in the global mode can decrease the ultimate strength by more than 13%. In the worst case among the global modes, the strength is reduced by 31% for a 20 mm imperfection. In marine structures, stiffeners buckle after plate buckling and thus carry the resulting loads. Hence, stiffeners' strength and their imperfections exert a considerable effect on stiffened plates' ultimate strength.

In this study, various geometric imperfection shapes are considered. For each imperfection shape, various magnitudes are studied. In this section, some cases are explored in detail.

4.1 Case One: No imperfection

For the perfect stiffened composite plate, the results of the finite element analysis are shown in Figure 7. The horizontal axis represents the longitudinal deformation of boundary 2, called Δ (Figure 1), and the vertical axis is the applied longitudinal load. In Figure 7, the behavior of the stiffened composite plate is initially linear, and all structural components are in the linear elastic region. When the first ply failure occurs in the layers with a 45° fiber angle, it quickly progresses and spreads to all layers. Following these failures, the stiffness of the stiffened composite plate and the P- Δ curve slope decrease. By increasing the forced displacement on line CD thereafter, the behavior of the stiffened composite plate becomes bilinear until the plate panel buckles in 5 half-waves (first eigenvalue buckling mode), and the stiffness of the plate decreases again. Subsequently, the plate reaches its ultimate strength, which is equal to 1.08 MN. Increasing the forced displacement at boundary 2 eventually causes the stiffened composite plate to become unstable following the stiffeners' buckling.

Table 2: Deformation and progress of damage in layers 1 and 5 in plate panels

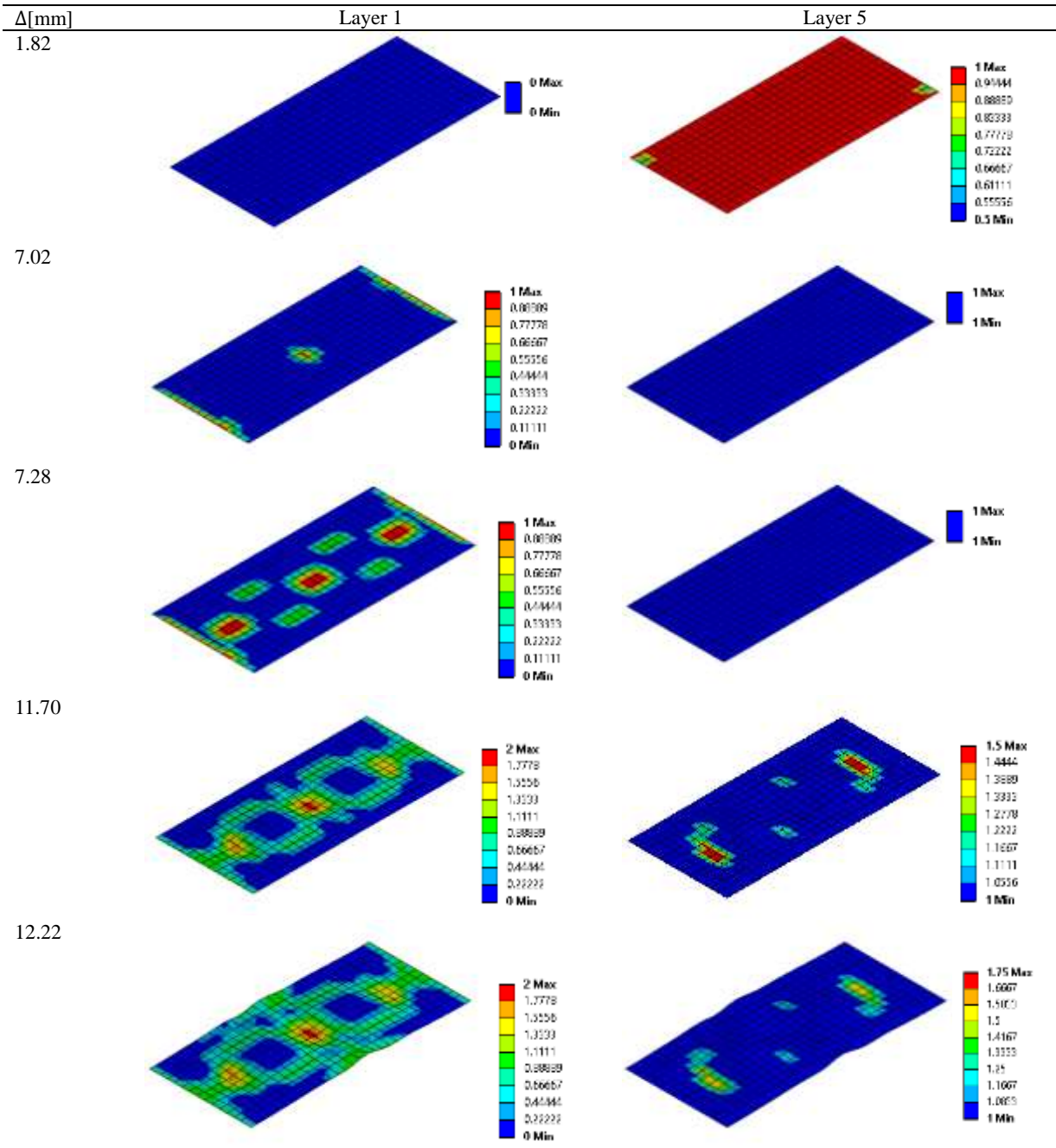

legend: 0 means no damage, 1 means initiation of damage, 2 means complete damage

Table 3: Deformation and progress of damage in layers 1 and 5 in the stiffeners

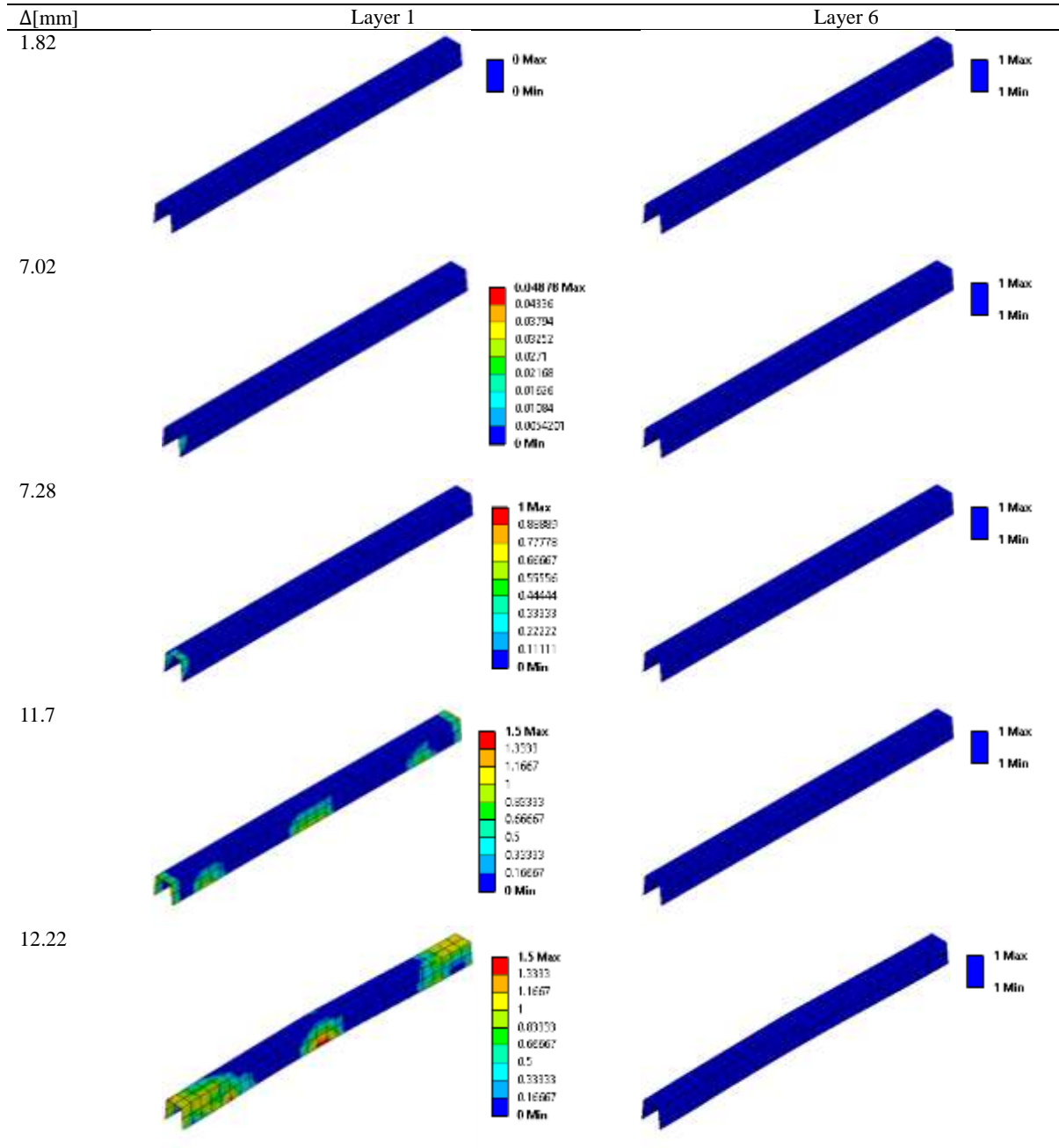

legend: 0 means no damage, 1 means initiation of damage, 2 means complete damage

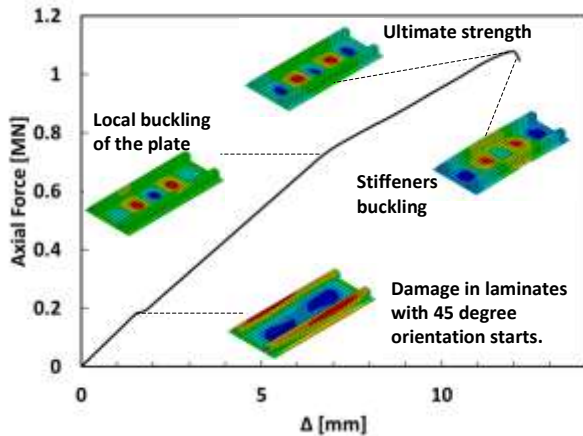

Figure 7: Longitudinal compression load versus longitudinal displacement for perfect stiffened composite plate

The deformation and damage propagation in the first and fifth layers of the plate panels and the first and sixth layers of the stiffeners for the perfect stiffened composite plate are presented in Tables 2 and 3, respectively. These layers are chosen as examples and as representatives of the other layers because of their similar behaviors.

The first and fifth layers are chosen as examples, and they can represent the behaviors of the other layers. In the perfect composite stiffened plate, when the displacement Δ reaches 5.98 mm, the first failure in the matrix of layer 1 occurs. This damage starts in the middle of lines AB and CD (Figure 1). Thereafter, the damage spreads fast along both boundaries. Then, at $\Delta = 7.06$ mm, the matrix damage at the middle of the plate starts to grow. At $\Delta = 7.8$ mm, fiber damage initiates at the same place. Eventually, as the fiber damage progresses to the sides, the stiffened composite plate reaches its ultimate strength. In layer 5, whose fiber orientation is equal to 45° , the matrix damage at $\Delta = 1.3$ mm initiates at the corners of the plate at the boundaries and progresses to the whole plate at a high rate. In layer 5, fiber damage also occurs in small regions before the plate reaches its ultimate strength. Table 4 illustrates the deformation and damage propagation in layers 1 and 6 of the stiffeners of the stiffened composite plate with no imperfection. In this case, in stiffener layer 1 at $\Delta = 7.5$ mm, the matrix damage starts in the middle and near the stiffeners' boundaries in the webs. By increasing the displacement to $\Delta = 11.44$ mm, the fiber damage starts in the middle of the stiffeners in the webs. Web damage also takes place in the webs and boundaries. In layer 6 of the stiffeners, the matrix damage in the boundaries at $\Delta = 1.56$ mm expands to the entire layer at a high rate; at $\Delta = 12.09$ mm, fiber damage is initiated in the middle of the stiffeners' webs.

4.2 Case 2: Imperfection mode 11 with a magnitude of 20 mm

In this case, the model and material properties are the same as those in Case 1, while the initial geometric imperfection

has the shape of the 11th buckling mode, and its magnitude is equal to 20 mm. The results for the 11th mode of imperfection with different magnitudes are presented in Figure 7. The magnitude of the imperfection exerts a dramatic effect on the postbuckling behavior of the stiffened composite plate. The imperfection magnitude of 20 mm of the 11th mode is chosen to study in detail the imperfection effect on buckling and postbuckling.

Table 4: Damage sequence in stiffened plate

Δ [mm]	Layer no.	Plate / Stiffeners	Fiber/ Matrix Damage	Damage Location
1.3	5 th	plate	Matrix	Corners of the plate
1.56	6 th	stiffeners	Matrix	Boundaries
5.98	1 st	plate	Matrix	Middle of boundary 1 and boundary 2
7.06			Local buckling of the plate	
7.06	1 st	plate	Matrix	Middle of the plate
7.50	1 st	stiffeners	Matrix	Middle and near of the boundaries in the webs
7.80	1 st	plate	Fiber	Middle and near of the boundaries in the webs
12.09	6 th	stiffeners	Fiber	middle of the webs
12	5 th	stiffeners	Fiber	Middle of the stiffeners

Different from the case of the perfect plate, the buckling mode of the plate under the 11th imperfection mode with a magnitude of 20 mm (Tables 5 and 6) is not apparent. The damage in the plate and stiffeners starts with matrix damage in the layers with a fiber orientation of 45° at $\Delta = 0.5$ mm, and the damage spreads through these layers rapidly. Consequently, the slope of the P- Δ curve (Figure 8) decreases. In other layers, matrix damage starts at $\Delta = 3.5$ mm in the middle part of the plate and boundaries.

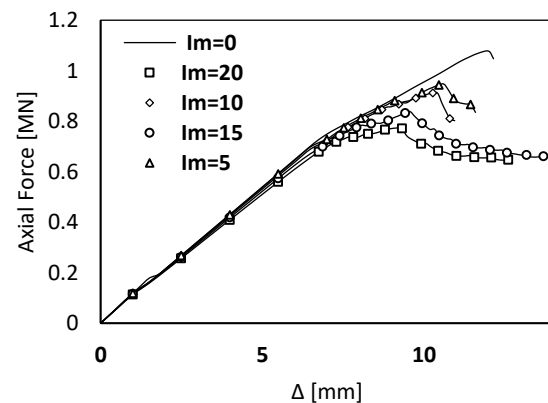

Figure 8: Longitudinal compression load versus longitudinal displacement for mode 11, I_m is the magnitude of the imperfection

Meanwhile, fiber damage starts in the layers with a fiber orientation of 0° at $\Delta = 7.675$ mm and spreads to the adjacent layers at $\Delta = 9.7$ mm. Then, at $\Delta = 7.15$ mm, the fiber damage in the boundaries of the stiffeners starts. At $\Delta = 9.325$ mm, fiber damage begins at the middle of the stiffeners' table in layers with a fiber orientation of 0° and spreads to the stiffeners' webs. At $\Delta = 9.7$ mm, this damage spreads to all the layers in the middle of the table. When the stiffener fibers in the stiffeners' table and webs fail, the stability of the stiffened composite plate is lost. Comparing these two cases shows that initial geometric imperfection modes and magnitudes can change the ultimate strength and postbuckling behavior of stiffened composite plates. This result should be considered in the analysis of the strength of these structures.

5 Conclusions

In this work, a series of nonlinear finite element and progressive failure was performed on a stiffened composite plate with a wide range of initial geometric imperfections. The plate is subjected to an in-plane compression load. For all imperfection cases, the P- Δ curves are derived, and the effects of different imperfections are studied. The results can be summarized as follows:

1. All the P- Δ charts suggest that designing a stiffened composite plate on the basis of the first ply failure is not accurate and underestimates the strength of the plate. In all cases, the stiffened composite plate's ultimate strength exceeds the first ply failure's strength (Figure 6).
2. The initial imperfection can be categorized into two groups, namely, local and global modes. In the local mode of initial geometric imperfections, the stiffeners are in perfect shape, and only the plate panels are deformed. In the global mode, the stiffeners show bending or torsional deformation. These results indicate the following:
 - a. A 20 mm local geometric imperfection can reduce the stiffened plate's ultimate strength by 13%;
 - b. A 20 mm global geometric imperfection can decrease the stiffened plate's ultimate strength by 31%.
3. Global mode shapes can decrease the ultimate strength of stiffened plates dramatically. For example, all the six worst cases herein, including modes 7, 8, 9, and 11, show global mode shapes.
4. In addition to buckling mode shapes, three sets of combinations of the worst cases are studied. If a geometrical imperfection shape is a combination of three buckling mode shapes, then the postbuckling behavior of the plate under such combination is almost the same as that in the global mode.
5. The postbuckling behavior of the plate highly depends on the plate imperfection mode, especially

for large imperfections. Thus, we highly recommend that the initial geometric imperfections in the global mode be investigated during the design phase and be limited during the manufacturing and surveying phases of the production of stiffened composite plates.

References

- Ambur, DR, Jaunky, N, Hilburger, MW, 2004. Progressive failure studies of stiffened panels subjected to shear loading. *Composite Structures*, **65**(2), 129–142. DOI: 10.1016/S0263-8223(03)00153-3
- Anyfantis, KN, 2019. Evaluating the influence of geometric distortions to the buckling capacity of stiffened panels. *Thin-Walled Structures*, **140**, 450–465. DOI: 10.1016/j.tws.2019.03.057
- Anyfantis, KN, Tsouvalis, NG, 2012. Post Buckling Progressive Failure Analysis of Composite Laminated Stiffened Panels. *Applied Composite Material*, **19**, 219–236. DOI: 10.1007/s10443-011-9191-1
- Assaee, H, Ovesy, H, Hajikazemi, M, 2012. A semi-energy finite strip non-linear analysis of imperfect composite laminates subjected to end-shortening. *Thin-Walled Structures*, **60**, 46–53. DOI: 10.1016/j.tws.2012.06.011
- Bai, R, Bao, S, Lei, Z, Liu, C, Chen, Y, Liu, D, Yan, C, 2018. Experimental study on compressive behavior of I-stiffened CFRP panel using fringe projection profilometry. *Ocean Engineering*, **160**, 382–388. DOI: 10.1016/j.oceaneng.2018.04.085
- Barsotti, B, Gaiotti, M, Rizzo, CM, 2020. Recent Industrial Developments of Marine Composites Limit States and Design Approaches on Strength. *Journal of Marine Science and Application*, **19**, 553–566. DOI: 10.1007/s11804-020-00171-1
- Pal, P, Bhattacharyya, SK, 2007. Progressive Failure Analysis of Cross-ply Laminated Composite Plates by Finite Element Method. *Journal of Reinforced Plastics and Composites*, **26**(5), 465–477. DOI: 10.1177/0731684406072533
- Bisagni, C, Vescovini, R, 2009. Analytical formulation for local buckling and post-buckling analysis of stiffened laminated panels. *Thin-Walled Structures*, **47**(3), 318–334. DOI: 10.1016/j.tws.2008.07.006
- Chen, NZ, Guedes Soares, C, 2007. Progressive failure analysis for prediction of post-buckling compressive strength of laminated composite plates and stiffened panels. *Journal of Reinforced Plastics and composites*, **26**(10), 1021–1042. DOI: 10.1177/0731684407079422
- Chen, NZ., Guedes Soares, C, 2007. Reliability assessment of post-buckling compressive strength of laminated composite plates and stiffened panels under axial compression. *International Journal of Solids and Structures*, **44**(22-23), 7167–7182. DOI: doi.org/10.1016/j.ijsolstr.2007.04.002
- Chen, NZ, Guedes Soares, C, 2008. Spectral stochastic finite element analysis for laminated composite plates. *Computer Methods in Applied Mechanics and Engineering*, **197**(51–52), 4830–4839. DOI: doi.org/10.1016/j.cma.2008.07.003
- Chen, NZ, Guedes Soares, C, 2008. Ultimate Longitudinal Strength of Ship Hulls of Composite Materials. *Journal of Ship Research*,

- 52(3), 184-193. DOI: 10.5957/jsr.2008.52.3.184
- Elseifi, MA, Gurdal, Z, Nikolaidis, E, 1999. Convex/Probabilistic Models of Uncertainties in Geometric Imperfections of Stiffened Composite Panels. *AIAA JOURNAL*, **37**(4), 468-474. DOI: 10.2514/2.757
- Gaitanelis, DG, Giannopoulos, IK, Theotokoglou, EE, 2019. Numerical FEA parametric analysis of CAI behaviour of CFRP stiffened panels. *Thin-Walled Structures*, **143**, 106231. DOI: 10.1016/j.tws.2019.106231
- Ghannadpour, SAM, Abdollahzadeh, N, 2020. Progressive failure analysis of thick imperfect composite plates using nonlinear plate theory. *International Journal of Non-Linear Mechanics*, **121**, 103292. DOI: 10.1016/j.ijnonlinmec.2019.103292
- Ghannadpour, SAM, Shakeri, M, 2018. Energy based collocation method to predict progressive damage behavior of imperfect composite plates under compression. *Latin American Journal of Solids and Structures*, **15**(4), 35. DOI: 10.1590/1679-78254257
- Ghannadpour, S, Barekati, M, 2016. Initial imperfection effects on postbuckling response of laminated plates under end-shortening strain using Chebyshev techniques. *Thin-Walled Structures*, **106**, 484-494. DOI: 10.1016/j.tws.2016.03.028
- Ghannadpour, S, Shakeri, M, 2020. Application of a new energy-based collocation method for nonlinear progressive damage analysis of imperfect composite plates. *Thin-Walled Structures*, **147**, 106369. DOI: 10.1016/j.tws.2019.106369
- Hashin, Z, 1980. Failure Criteria for Unidirectional Fiber Composites. *Journal of Applied Mechanics*, **47**(2), 329-3334. DOI: 10.1115/1.3153664
- Huang, L, Sheikh, AH, Ng, CT, Griffith, MC, 2015. An efficient finite element model for buckling analysis of grid stiffened laminated composite plates. *Composite Structures*, **122**, 41-50. DOI: 10.1016/j.compstruct.2014.11.039
- Karrech, A, Elchalakani, M, Attar, M, Seibi, A, 2017. Buckling and post-buckling analysis of geometrically non-linear composite plates exhibiting large initial imperfections. *Composite Structures*, **174**, 134-141. DOI: 10.1016/j.compstruct.2017.04.029
- Kong, CW, Lee, IC, Kim, CG, Hong, CS, 1998. Postbuckling and failure of stiffened composite panels. *Composite Structure*, **42**(1), 13-21. DOI: 10.1016/S0263-8223(98)00044-0
- Mittelstedt, C, Erdmann, H, Schröder, KU, 2011. Postbuckling of imperfect rectangular composite plates under inplane shear closed-form approximate solutions. *Archive of Applied Mechanics*, **81**, 1409-1426. DOI: 10.1007/s00419-010-0491-y
- Mittelstedt, C, Schroder, KU, 2010. Postbuckling of compressively loaded imperfect composite plates: closed-form approximate solutions. *International Journal of Structural Stability and Dynamics*, **10**(4), 761-778. DOI: 10.1142/S0219455410003725
- Morshedsolouk, F, Khedmati, MR, 2014. Parametric study on average stress-average strain curve of composite stiffened plates using progressive failure method. *Latin American Journal of Solids and Structures*, **11**(12), 2203-2226. DOI: 1590/S1679-78252014001200005
- Murugesan, N, Rajamohan, V, 2017. Prediction of Progressive Ply Failure of Laminated Composite Structures: A Review. *Archives of Computational Methods in Engineering*, **24**, 841-853. DOI: 10.1007/s11831-016-9191-2
- Namdar, Ö, Darendeliler, H, 2017. Buckling, postbuckling and progressive failure analyses of composite laminated plates under compressive loading. *Composites Part B: Engineering*, **120**, 143-151. DOI: 10.1016/j.compositesb.2017.03.066
- PAL, P, RAY, C, 2002. Progressive Failure Analysis of Laminated Composite Plates by Finite Element Method. *Journal of Reinforce Plastics and Composites*, **21**(16), 1502-1513. DOI: 10.1177/0731684402021016488
- Priyadharshani, SA, Prasad, AM, Sundaravadivelu, R, 2017. Analysis of GFRP stiffened composite plates with rectangular cutout. *Composite Structures*, **169**, 42-51. DOI: 10.1016/j.compstruct.2016.10.054
- Smith CS., Dow RS, 1985, Compressive Strength of Longitudinally Stiffened GRP Panels. In: Marshall I.H. (eds) *Composite Structures 3*. Springer, Dordrecht. DOI:10.1007/978-94-009-4952-2_33
- Stamatelos, DG, Labeas, GN, Tserpes, KI, 2011. Analytical calculation of local buckling and post-buckling behavior of isotropic and orthotropic stiffened panels. *Thin-Walled Structures*, **49**(3), 422-430. DOI: 10.1016/j.tws.2010.11.008
- Tran, KL, Douthe, C, Sab, K, Dallot, J, Davaine, L, 2014. Buckling of stiffened curved panels under uniform axial compression. *Journal of Constructional Steel Research*, **103**, 140-147. DOI: 10.1016/j.jcsr.2014.07.004
- Zhu, S, Yan, J, Chen, Z, Tong, M, Wang, Y, 2015. Effect of the stiffener stiffness on the buckling and post-buckling behavior of stiffened composite panels – Experimental investigation. *Composite Structures*, **120**, 334-345. DOI: j.compstruct.2014.10.021